



CUDA[®]
AQUEOUS PARTS WASHERS

2412

AUTOMATIC PARTS WASHER

■ 1.043-356.0

■ 1.043-379.0

■ 1.043-357.0

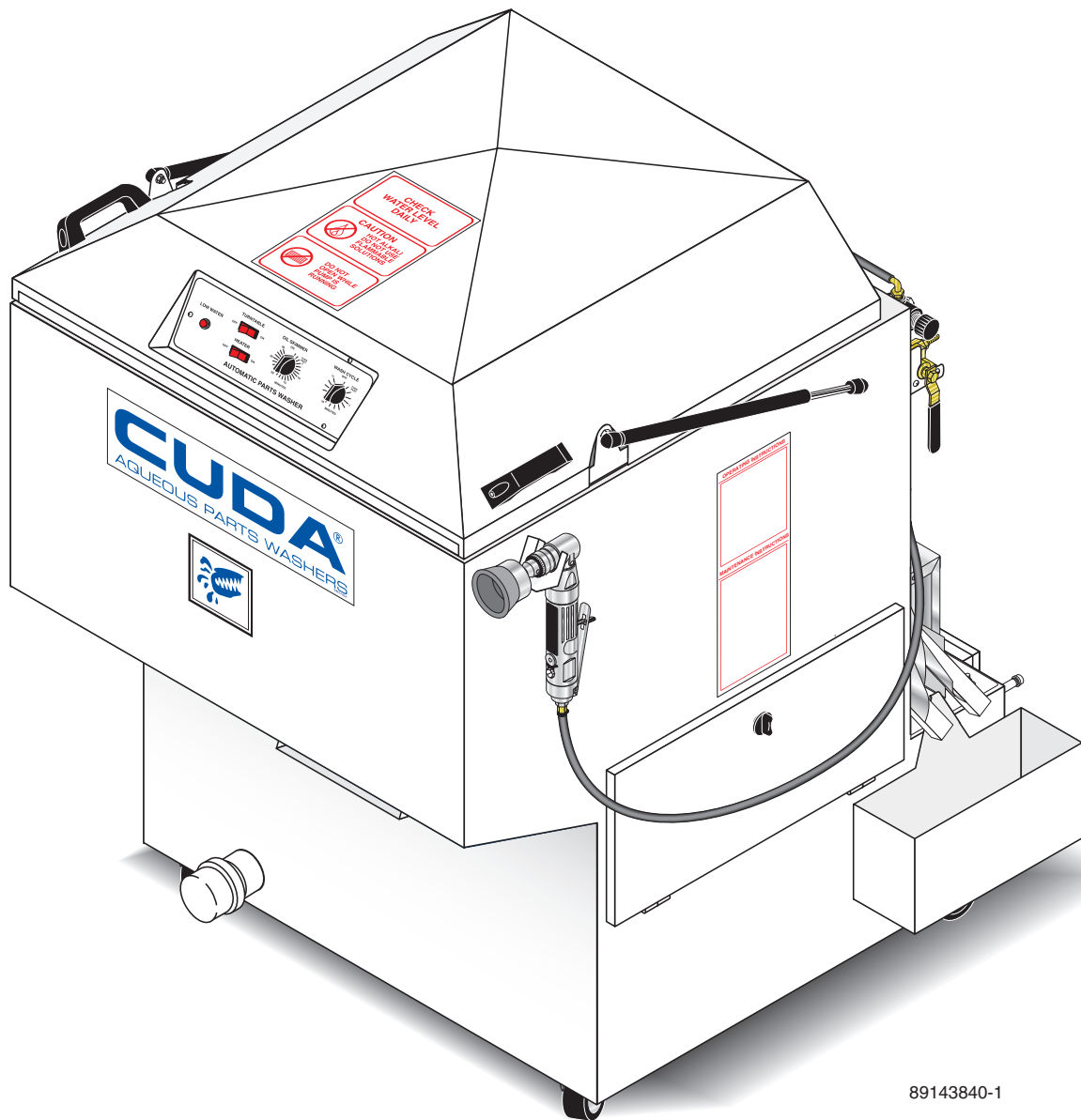

89143840-1

For technical assistance or the Kärcher dealer nearest you,
visit our website at www.CudaUSA.com

8.914-384.0

CONTENTS

SECTION 1 Introduction and Safety

General Safety Information	4-5
Component Identification	6-7

SECTION 2 Installation

Before you Begin	8
Step 1: Make Electrical Connections	8
Step 2: Connect a Compressed-Air Line and Accessories	8
Step 3: Connect a Water Line	8-9
Step 4: Fill the Machine with Water and Add Detergent	9

SECTION 3 Operation

Main Operating Components	10-13
Detergents and Additives	13-14
Preparing the Machine for Use	14
Shutting Down the Machine	14

SECTION 4 Troubleshooting

Troubleshooting Guides	15-16
Troubleshooting the Electrical System	17
Testing Individual Components	18

SECTION 5 Maintenance and Repair

Maintaining the Machine	19
Repairing the Machine	20
Heating Element	20
Thermostat	21
Timers and Switches on the Control Panel	21
Torque Limiter	22
Turntable Motor	22-23
Using the Oil Skimmer System	23

Exploded View and Parts List, 115V Electrical Panel	24-25
Exploded View and Parts List, 230V Electrical Panel	26-27
Exploded View and Parts List, Front View	28-29
Exploded View and Parts List, Rear View	30-31
Exploded View and Parts List, Auto Fill, Detail Brush, Power Brush	32-33
Exploded View and Parts List, Filter Option 8.725-269.0	34
Oil Skimmer	35
WARRANTY	

Model Number _____

Serial Number _____

Date of Purchase _____

The model and serial numbers will be found on a decal attached to the parts washer. You should record both serial number and date of purchase and keep in a safe place for future reference.

SECTION 1: INTRODUCTION

This manual is intended as a guide for safely installing, operating and maintaining your Automatic Parts Washer.

We reserve the right to make changes at any time without incurring any obligation.

Owner/User Responsibility:

The owner and/or user must have an understanding of the manufacturer's operating instructions and warnings before using this machine. Warning information should be emphasized and understood. If the operator is not fluent in English, the manufacturer's instructions and warnings shall be read to and discussed with the operator in the operator's native language by the purchaser/owner, making sure that the operator comprehends its contents.

Owner and/or user must study and maintain for future reference the manufacturers' instructions.

This manual should be considered a permanent part of the machine and should remain with machine if resold.

When ordering parts, please specify model and serial number.

GENERAL SAFETY INFORMATION

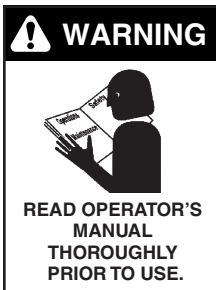

CAUTION: To reduce the risk of injury, read operating instructions carefully before using.

1. Read the owner's manual thoroughly. Failure to follow instructions could cause a malfunction of the parts washer and result in death, serious bodily injury and/or property damage.
2. Improper installation could cause serious injury to the machine. All installations must comply with local codes. Contact your electrician, plumber, utility company or the selling distributor for specific details.
3. The machine can only operate on the type of electrical power indicated on the electrical specifications tag. Operating the machine on any other power supply will permanently damage the motors.



WARNING: Electrical shock could cause serious injury or death.

4. Install the machine in compliance with the National Electric Code, connect it to a properly sized lockable disconnect and ground the machine using the grounding stud inside the main electrical panel.
5. While operating the machine, keep all electrical panels in place and securely fastened at all times.
6. Disconnect the machine completely from the outside power source before servicing.



WARNING: Hot, high pressure cleaning solution could cause serious injury.

7. Do not operate the machine with the lid or door open and do not override the safety switch.
8. After the machine stops, wait 10 seconds before opening the lid or door.



WARNING: Always wear approved eye protection and protective clothing while operating machine.

9. Always wear rubber gloves when loading and unloading the machine or servicing components in the processing chambers or sumps.
10. Maintain an unobstructed work area around the machine and keep the floor free of water, oil, grease or other foreign substances.

WARNING: Slips and falls from wet surfaces could cause serious injury.

This Automatic Parts Washer is designed to operate safely and efficiently with required maintenance. Before you begin to install and use the machine, please familiarize yourself with the major components.

SECTION 1: INTRODUCTION & SAFETY



WARNING: *Flammable liquids can create fumes which can ignite causing property damage or severe injury.*

12. Do not locate this machine in the vicinity of any flammable vapors, liquids or solids.
13. Before servicing the machine, refer to all MSDS's on

the material identified in the waste stream. You must comply with all warnings and wear all protective clothing stated on the MSDS.

14. When the machine is working, do not cover or place in a closed space where ventilation is insufficient. Avoid installing machines in small confined areas.
15. In cold climates, this parts washer will freeze if not in operation and must be located in a heated enclosure.
16. Running this machine without water will damage the heating elements and will void the warranty.

WARNING: *This is a heated parts cleaner. Use only nonflammable, noncombustible, water-based cleaning compounds in this machine. Do not fill or contaminate with any flammable or combustible material such as gasoline, alcohol, mineral spirits, etc. Drain parts to be cleaned of any combustible or flammable material before placing inside cabinet. Failure to observe this warning will create an extremely hazardous condition.*

17. All installations must comply with local codes. Contact your electrician, plumber, utility company or the selling distributor for specific details.
18. To protect the operator from electrical shock, the machine must be electrically grounded. It is the responsibility of the owner to connect this machine to a grounded receptacle of proper voltage and amperage ratings. Do not touch machine with wet hands or while standing in water. Always disconnect the power before servicing.
19. Never make adjustments on machine while it is in operation except those prescribed in this manual.



WARNING: *Use extreme caution when opening the door of this parts washer. Hot water/detergent vapors will be emitted. Stand Back!*

20. Do not allow high concentrations of flammable fluids, acids, or caustics to be introduced into this machine.

This automatic parts washer is designed to operate safely and efficiently. Before you begin to install and use the machine, please familiarize yourself with the major components.

SECTION 1: COMPONENT IDENTIFICATION - FRONT VIEW

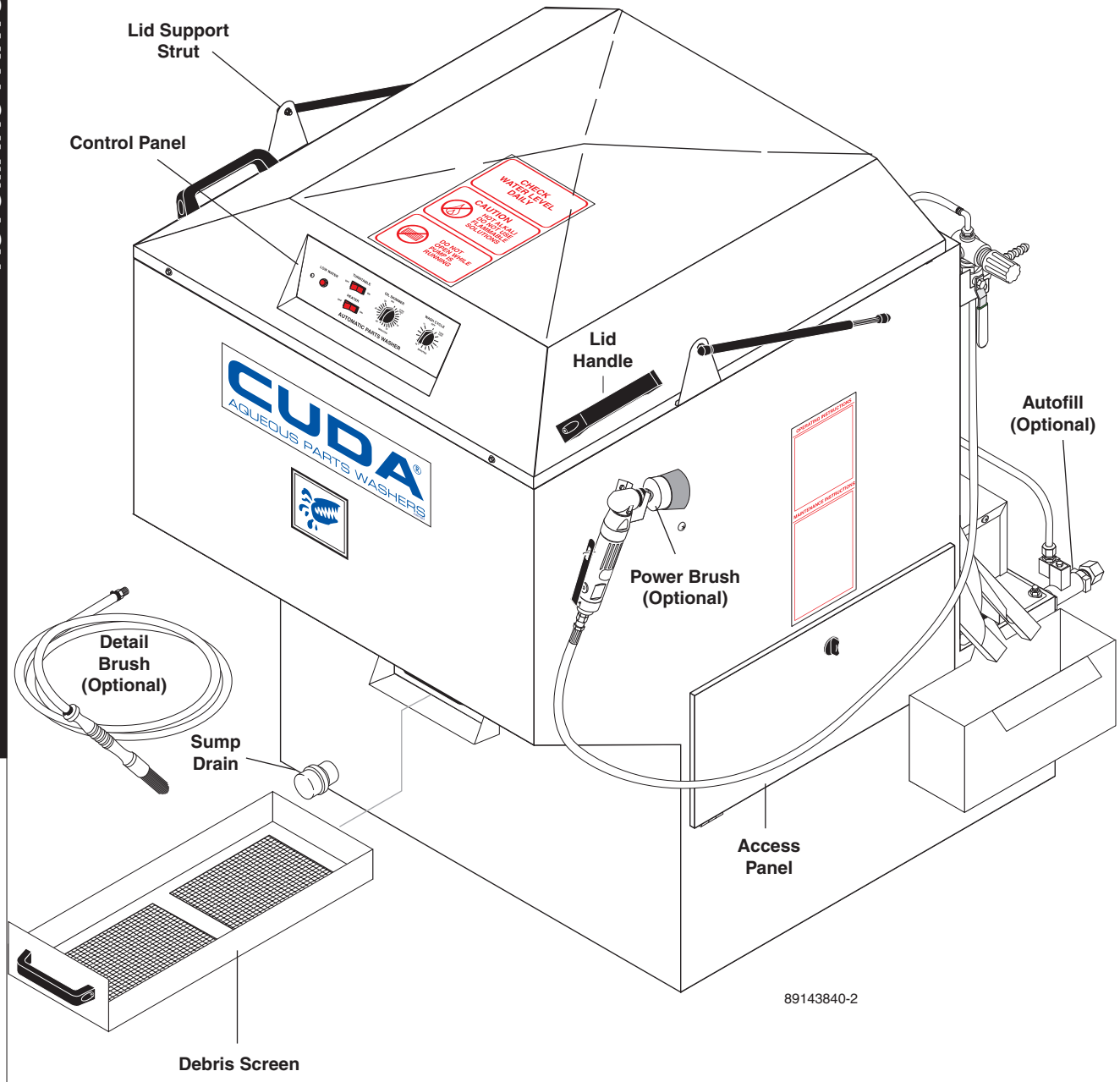

89143840-2

SECTION 1: COMPONENT IDENTIFICATION - REAR VIEW

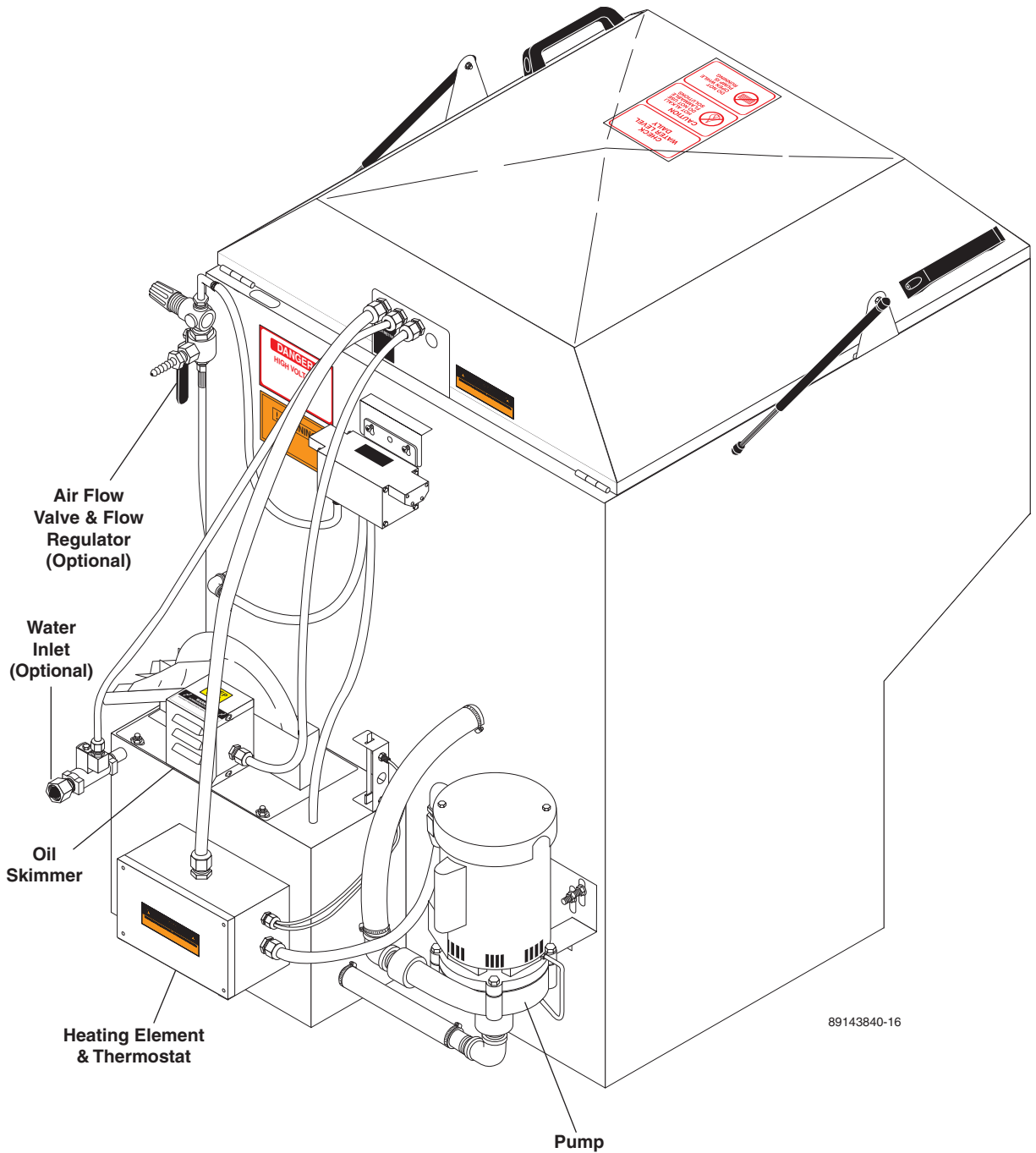

89143840-16

SECTION 2: INSTALLATION

BEFORE YOU BEGIN

To prepare to install the machine, choose an unobstructed, level site that allows convenient access for operators and maintenance personnel. Sources for water and electrical power should be located near the installation site. **If your machine is equipped with the optional power brush and hand detail brush you must also run a compressed air line to the installation site.**

If you have any questions regarding the installation, please contact your distributor and have the machine identification number available for the distributor to reference. Your machine identification tag is located inside the front cover of this manual for detailed machine specifications.

STEP 1: MAKE ELECTRICAL CONNECTIONS

NOTE: All electrical installation tasks must be performed by a licensed, professional electrician to ensure safe and proper operation. The installation must comply with the National Electric Code and all applicable state and local codes.

The machine can only operate on the type of electrical power indicated on the machine identification tag. Read and understand the machine identification tag to determine the electrical power requirements before installing the machine.

STEP 2: CONNECT A COMPRESSED-AIR LINE AND ACCESSORIES (OPTIONAL)

This step is required for machines equipped with the optional power brush and hand detail brush.

If your machine does not have these options, skip the following procedure.

NOTE: To ensure proper operation and to minimize the possibility of premature component failure, make sure the compressed air is supplied at 75 to 90 psi. We also recommend an in-line moisture trap and an in-line lubricator on the main air supply line. Refer to the documentation provided with the power brush for more information.

Step 1:

Remove the power brush from the box, install the wire brush in the chuck, and connect the air hose.

Step 2:

Familiarize yourself with the three-way air flow valve (See Figure Below), then install a fitting (if necessary)

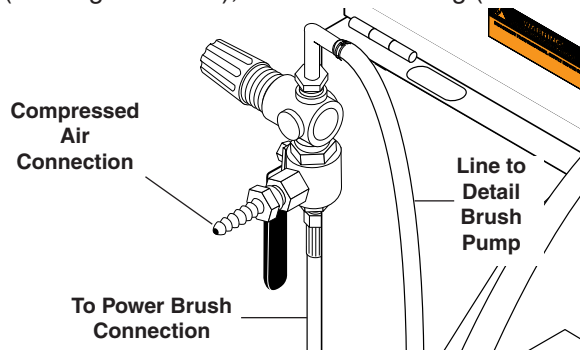

to accommodate a connection to your compressed-air supply.

Step 3:

Connect the shop compressed-air line to the machine.

Step 4:

Connect the hose from the power brush to the air flow valve.

Step 5:

Hang the power brush on the bracket mounted along the right side of the machine.

STEP 3: CONNECT A WATER LINE

This step is required for machines equipped with the optional automatic water fill feature. If your machine does not have this option, skip this step.

The optional automatic water fill feature automatically maintains the correct water level in the sump. The feature requires that you connect the machine to a dedicated water supply line.

To connect the machine to a water supply line, attach a suitable burst-proof hose to the hose connection on the rear of the machine (See Figure Below), then connect the hose to a nearby water spigot.

NOTE: The machine is designed for portability, and some maintenance tasks require that you move the machine. **DO NOT** make a permanent connection from your shop water supply to the machine.

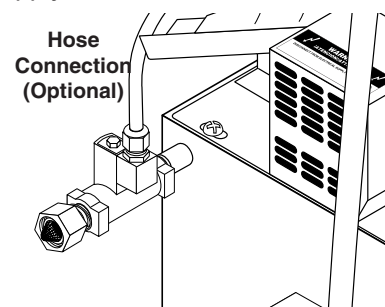

SECTION 2: INSTALLATION

STEP 4: FILL THE MACHINE WITH WATER AND ADD DETERGENT

Step 1:

Familiarize yourself with the low water shut-off system on the left side of the machine (See Figures Below).

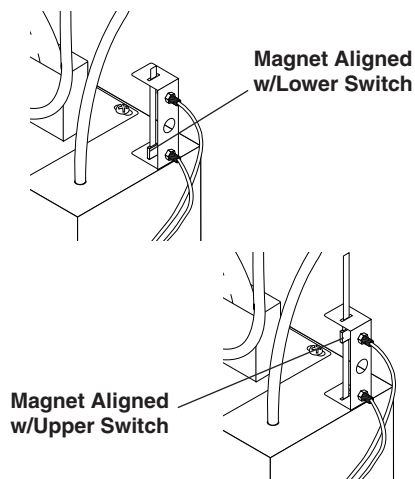

Step 2:

Fill the sump with water.

If your machine is equipped with the optional automatic water fill feature, simply turn the water on; the automatic water fill feature will automatically turn off the water when the sump is full.

If your machine is not equipped with optional automatic water fill feature, add water through the wash chamber until the low water shut-off system indicates that the sump is full. The sump capacity is 25 gallons.

Step 3:

Close the lid.

Step 4:

Flip the heater switch to the **ON** position.

The sump water will reach operating temperature (160°-180°F Excludes 120V Version 1.043-356.0) in approximately four hours.

To avoid having to wait for the wash solution to heat up before you use the machine each day, install an optional 24-hour 7-day heater timer. Refer to 24-hour, **7-day Heater Timer** for more information.

IMPORTANT: Allow the sump water to reach operating temperature before adding detergent and running the machine. If you add detergent and run the machine

when the sump water is cool, the detergent will foam excessively and could overflow the machine.

Step 5:

While the sump water is heating, add the appropriate quantity of factory approved detergent to the wash chamber. We recommend mixing the detergent with warm water in a separate bucket/container and then pouring the dissolved detergent into the sump.

NOTE: Factory approved detergent is the only detergent approved for use with this automatic parts washer. It is specially formulated with rust inhibitors and anti-foaming agents to optimize performance and minimize maintenance. The use of any other detergent during the warranty period will void the warranty. In addition, using factory detergents will extend your 90 day labor warranty to 1 year.

Step 6:

Turn the wash cycle timer and allow the machine to complete the cycle to dissolve the detergent into the water. When the machine stops, it is ready for use. Refer to **Operation** for complete operating instructions.

SECTION 3: OPERATION

MAIN OPERATING COMPONENTS

Familiarize yourself with the main operating components before operating the machine.

Control Panel

The control panel is located on the front center of the lid. It contains the heater, wash cycle, turntable controls, and low water indicator (See Figure Below).

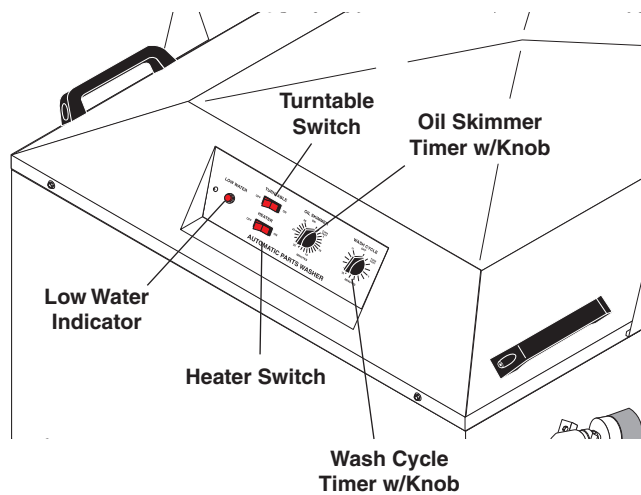

Low Water Indicator

The low water indicator light illuminates if the wash solution in the sump is low. For more information refer to **Low Water Shut-off System**.

Turntable Switch

The turntable switch is an illuminated rocker switch that enables you to disconnect power to the turntable motor. Set to **ON**, the turntable rotates during the wash cycle. Set to **OFF**, the turntable does not rotate during the wash cycle. The switch is useful for washing large parts that would otherwise impede turntable rotation.

Heater Control

The heater control is an illuminated rocker switch. It controls the heating element in the sump chamber. The heater control illuminates when the heating system is on. The heating system is thermostatically set at the factory to reach a high temperature of 180 °F (Excludes 120V Version 1.043-356.0). The temperature is adjustable using the thermostat (See **Thermostat**).

NOTE: The machines contain an internal power relay that automatically disconnects power to the heater when the pump turns on; the heater and pump cannot run simultaneously (120V only). After long wash cycles it may be necessary to let the machine sit idle for a period of time to allow the wash solution to reheat to operating temperature.

Wash Cycle Control

The wash cycle control is a timer switch. When set, the timer automatically shuts off the pump and turntable when the wash cycle is complete.

Thermostat

The thermostat is located inside pump enclosure. The thermostat is factory-set to heat the wash solution to a maximum temperature of 180°F (Excludes 120V Version 1.043-356.0).

Adjusting the Thermostat

To adjust the thermostat, rotate the adjustment screw or knob clockwise to increase the temperature, or counterclockwise to decrease the temperature (See Figure Below).

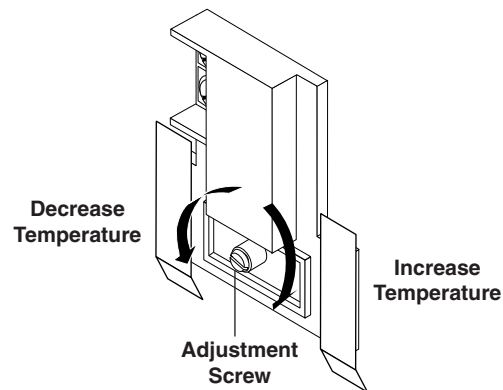

24-hour, 7-day Heater Timer

A 24-hour, 7-day heater timer is available as an option on these machines. The timer plugs directly into a 15-amp outlet and automatically cycles the heating system on and off each day. To configure the timer, refer to the instructions printed on the back of the timer housing.

To order a 24-hour, 7-day heater timer, contact your distributor or call customer service.

Lid Safety Switch

The lid safety switch is located behind the front left lip of the lid, just below the control panel (See Figure Below). The safety switch disconnects power to the water pump and the turntable motor if the lid is raised during operation.

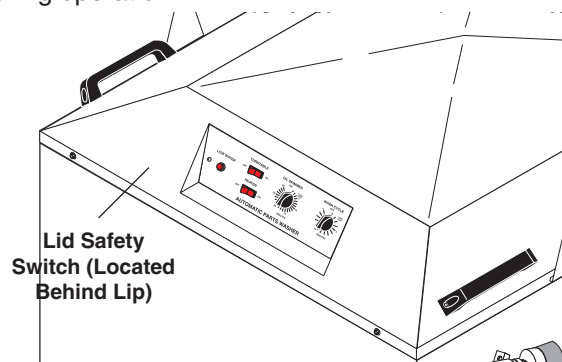

SECTION 3: OPERATION

Turntable Assembly

The turntable assembly uses a torque arm mounted on the underside of the lid to rotate the turntable (See Figure Below). The torque arm includes a torque limiter which prevents the turntable motor from burning out in case a part falls off the turntable and obstructs rotation. For information on adjusting the torque limiter, refer to **Torque Limiter**. For information on replacing the turntable motor, refer to **Turntable Motor**.

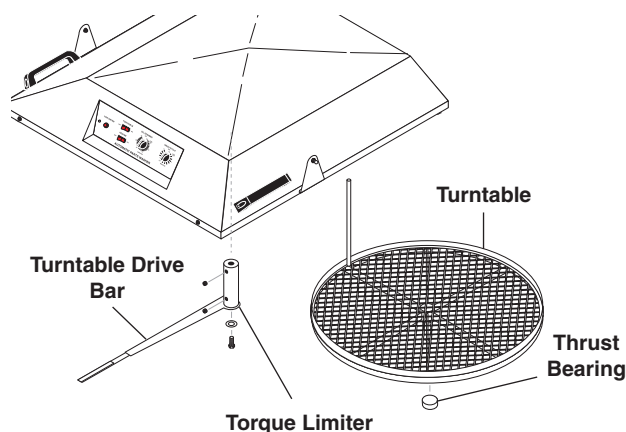

Removing the Turntable

To remove the turntable, grasp it evenly on opposite sides and lift it free of the spindle.

Important: The turntable rotates on a thrust bearing inside of the hub. As you lift the turntable free of the spindle, take care not to jar the thrust bearing loose. If the thrust bearing drops out of the hub, inspect it for wear then either replace it or re-install it (See Previous Figure).

Debris Screen

The debris screen is located below the turntable inside of the wash chamber (See Figure Below). The debris screen continuously filters debris particles from the cleaning solution to ensure blockage free spray nozzle operation, and also provides a safeguard against small

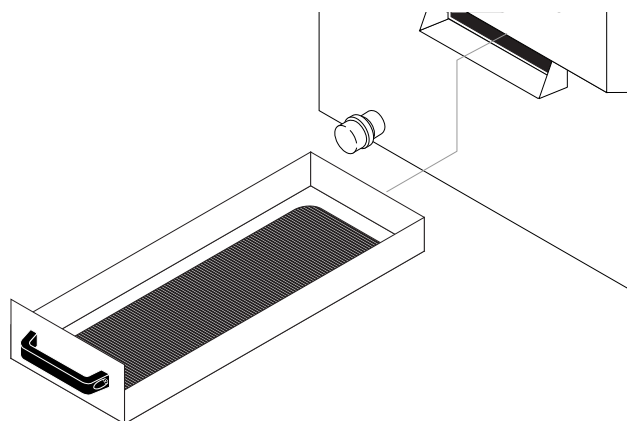

parts that might accidentally be washed through from the wash chamber.

The frequency at which you must clean the debris screen depends on machine usage. In general, you should clean the screen before operating the machine each day. To access and remove the screen you must remove the turntable (see **Removing the Turntable**).

NOTE: Never operate the machine without the debris screen in place. The screen is specially sized to filter particles that could clog the spray nozzles or damage the water pump. **Operating the machine without the debris screen in place could cause spray nozzle clogging or water pump failure.**

Air Flow Valve (Optional)

The air flow valve is located on the right rear corner of the machine. It is a three-way ball valve that controls the flow of compressed air to the power brush and the hand detail brush (See Figure Below).

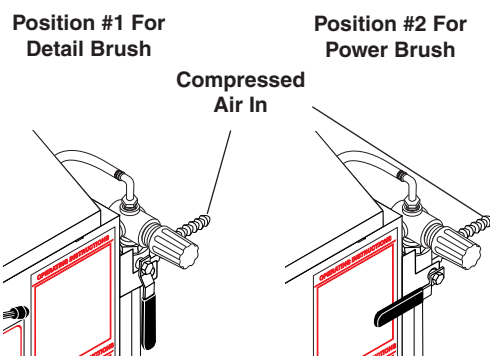

Power Brush (Optional)

The power brush is located on the right front corner of the machine (See Figure Below). Refer to **Connect a Compressed-Air Line and Accessories** for detailed installation information.

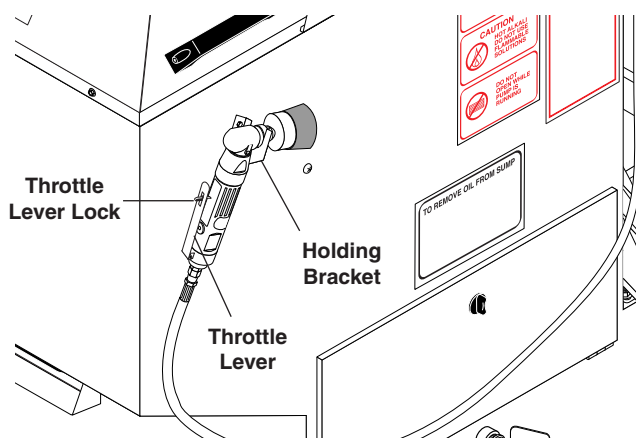

NOTE: The power brush is available as an option on this machine. For ordering information, contact your distributor or call customer service.

SECTION 3: OPERATION

Using the Power Brush

WARNING: *Particles dislodged by the power brush could cause serious injury to your eyes. Always wear approved eye protection when using the power brush.*

With stiff stainless steel bristles turning at 1800 RPM, the power brush easily removes carbon deposits, old gasket material, or other tightly-adhered materials from parts before washing.

To turn on the power brush, position the air flow select valve appropriately, then push the power brush lever lock forward with your thumb and squeeze the throttle lever to control the speed of the brush.

Detail Brush and Flow Regulator (Optional)

The detail brush is located on the front inside wall of the wash chamber. The flow regulator is located on the right rear corner of the machine (See Following Figure). The detail brush uses a continuous flow of hot cleaning solution through its nylon bristles to help you clean delicate or lightly soiled parts. The flow regulator controls the flow of cleaning solution through the detail brush.

WARNING: *Hot, high-pressured cleaning solution could cause serious injury. Always wear rubber gloves and approved eye protection when handling hot cleaning solution.*

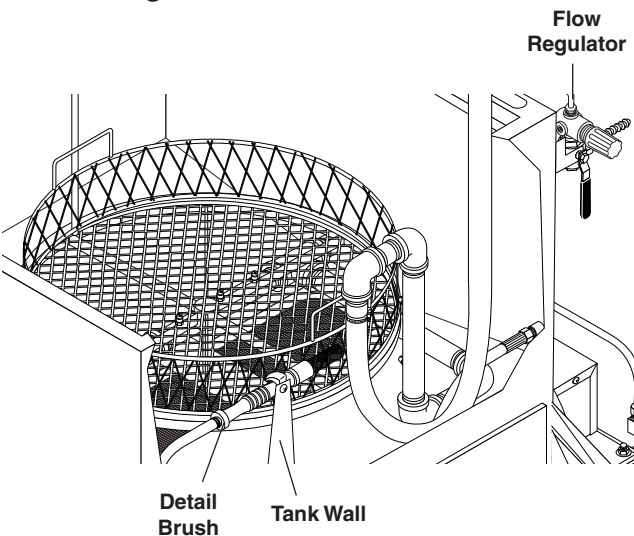

Adjusting the Flow of Cleaning Solution

The flow of cleaning solution through the detail brush is pre-set at the factory. If you need to adjust the flow, pull out the flow regulator knob, then rotate it clockwise to decrease the flow or counter-clockwise to increase the flow. After adjusting, push the knob back in to lock it.

NOTE: The detail brush is available as an option on this machine. For ordering information, contact your distributor or call customer service.

Automatic Oil Skimmer System

The automatic oil skimmer system consists of a skimmer assembly that includes an electric motor that rotates a disk in the sump water. The oil adheres to the disk and is wiped off by wiper blades and deposited in a container. The gear motor is controlled by a timer switch on the control panel. See information in Section 5 for detailed operation.

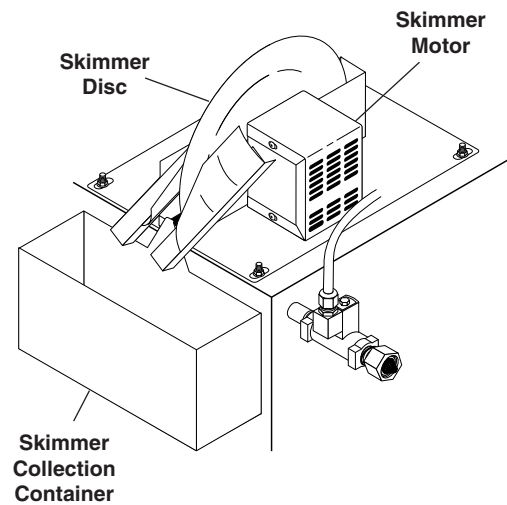

SECTION 3: OPERATION

WATER LEVEL OK:
Both switches OPEN, Automatic Water Fill Valve (if installed) CLOSED, Heating Element ON.

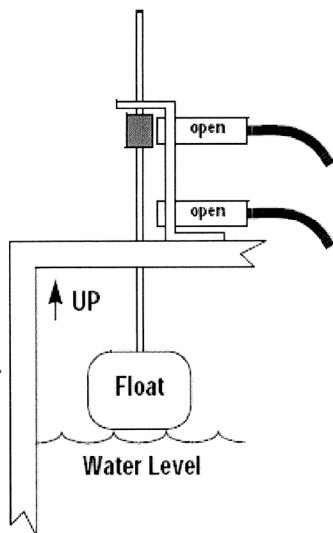

LOW WATER LEVEL:
Top switch CLOSED, Bottom Switch CLOSED, Automatic Water Fill Valve (if installed) OPEN, Heating Element OFF.

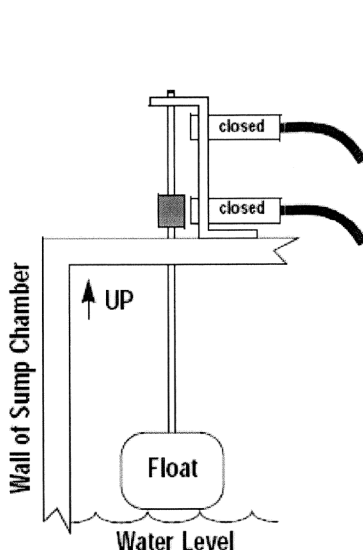

SUMP FILLING:
Top switch CLOSED, Bottom Switch OPEN, Automatic Water Fill Valve (if installed) OPEN, Heating Element OFF.

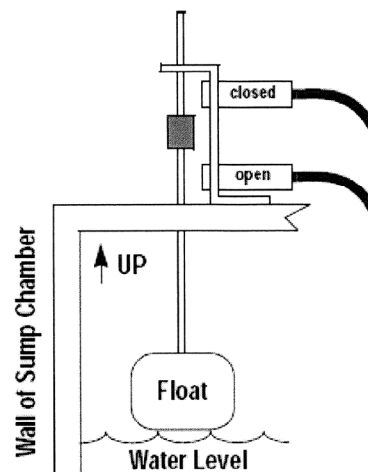

Low Water Shut-off System

The low water shut-off system shuts down the machine if the wash solution in the sump chamber drops below a safe level. The system uses two reed switches and a float rod mounted on the right outer wall of the sump chamber to control the water level (See Figure Below).

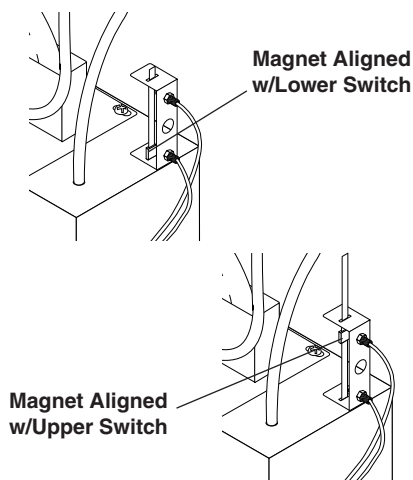

If the wash solution drops below the lower reed switch, the low water indicator light on the control panel turns on and the system disconnects power to the heating element, the pump, and the turntable motor. To reset the system, add water to the sump until the low water indicator light turns off.

Automatic Water Fill (Optional)

The automatic water fill system automatically maintains a proper water level in the sump. It is available as an option on these machines.

The automatic water fill system uses the low water shut-off reed switches to open and close a water solenoid valve, which automatically maintains a proper water level in the sump. The figure above describes the operation of the automatic water fill system.

DETERGENTS AND ADDITIVES

Detergents

Manufacturer's detergents are the only detergents approved for use with our Automatic Parts washers. They are specially formulated with rust inhibitors and anti-foaming agents to optimize performance and minimize maintenance. The use of any other detergent during the warranty period will void the warranty.

To monitor the relative concentration of the detergent in the wash solution, periodically examine the wash solution in the sump chamber for the following indicators:

- **Rust inside the machine:** not enough detergent
- **Excessive foaming:** not enough detergent
- **Thick, white residue on parts after washing:** too much detergent

To maintain proper detergent concentration under typical operating conditions, add detergent each month

SECTION 3: OPERATION

after cleaning the sump chamber. Follow recommended detergent quantities. Use pH kit to determine the proper amount of detergent to use. If you need help interpreting test results, contact customer service.

Rust Inhibitor Additive

Factory detergents protect the entire inside of your machine against the degenerative effects of water evaporation. A rust inhibitor additive actually evaporates with the water and continuously coats and protects metal surfaces, even while your machine is sitting idle. For more information, contact your distributor or call customer service.

PREPARING THE MACHINE FOR USE

Before you begin to wash parts, it is important that you properly prepare the machine. Before you begin to use the machine each day:

- check the water level and add water to the sump tank if necessary;
- heat the water to operating temperature
- add detergent if necessary (see **Detergents and Additives**);
- verify that none of the spray nozzles are clogged; and
- clean the debris screen.

WASHING PARTS

The following procedure assumes that the heater is on and the sump water is at operating temperature.

To wash parts, perform the following procedure.

WARNING: Hot, high-pressured cleaning solution could cause serious injury. Always wear rubber gloves and approved eye protection when loading and unloading the machine.

Step 1:

Load large, heavy parts directly onto the turntable. Load small, light parts in the optional small parts basket, if available. Make sure none of the parts extend beyond the edge of the turntable and make sure large, light parts (valve covers, for example) are secured to the turntable.

NOTE: For optimum cleaning performance, provide a slight clearance between parts to allow adequate flow of cleaning solution around and between them.

Step 2:

Close the lid.

NOTE: If you are washing large parts that might impede turntable rotation, flip the turntable switch **OFF**.

Step 3:

Set the wash cycle timer.

Step 4:

When the machine stops, lift the lid and wait a few moments to allow the parts to cool and dry before removing them. Most parts flash-dry in seconds.

SHUTTING DOWN THE MACHINE

To shut down the machine at the end of the day:

- set the wash cycle control to **OFF**;
- shut off the compressed air at the supply line (if installed).

WARNING

- **For periods of extended shut-down (weekends and holidays, for example), disconnect power to the machine.**
- **If your machine is equipped with an optional programmable heater timer, periodically verify the settings to prevent inadvertent unattended operation.**

SECTION 4: TROUBLESHOOTING

PROBLEM	POSSIBLE CAUSE	SOLUTION
POOR CLEANING PERFORMANCE	Turntable switch is OFF	Verify that the turntable switch is ON (See Turntable Switch).
	Parts are obstructing each other	Check the position of parts on turntable; position parts to allow flow of cleaning solution around and between them.
	Low water level in sump	Check sump water level; add water if necessary.
	Clogged or improperly aligned spray nozzles	Check spray nozzles for obstructions and alignment; clean and align if necessary (See Cleaning and Aligning the Spray Nozzles).
	Low detergent concentration 10-11 pH	Add 1-2 scoops of detergent and observe cleaning performance; add 1-2 scoops more if necessary. Measure pH.
	Wash solution is not properly heated	See <i>wash solution is not heating</i>
	Pump is not operating properly	See <i>pump does not operate properly</i> .
WASH SOLUTION NOT HEATING	Blown fuse	Refer to Troubleshooting the Electrical System .
	Low waterlevel in sump	Check the water level in the sump; add water if necessary (See Low Water Shut-Off).
	Thermostat is incorrectly set	Check thermostat setting; set to 180° (See Adjusting the Thermostat).
	Excess debris is built up around heating element	Check for debris buildup around heating element; clean out if necessary (See Cleaning out the Sump).
	Line voltage is too low	Contact a licensed electrician to verify that the incoming line voltage meets requirements.
	Failed heater timer	Test the heater timer; replace if necessary (See Wash Cycle and Heater Timers).
	Failed thermostat	Test the thermostat; replace if necessary (See Single Phase Thermostat , or contact dealer to test a three-phase thermostat).
	Failed heating element	Test the heating element; replace if necessary (See Single Heating Element , or contact dealer to test a three-phase heating element).
FOAMING	Machine operating with cold water	Bring water up to correct temperature
	Grease, high detergent motor oils, transmission oil, gear lubes	Do not place oil pan or transmission pan into machine without pouring oil out of it.
	Not enough detergent	Add more detergent, check pH level. Use defoamer.
WHITE POWDER ON PARTS	Solution is old	Change sump water and recharge with fresh detergent and vapor corrosion inhibitor.
	Water hardness and TDS (totally dissolved solids)	Use a water softener and/or change your sump water more frequently.
	Large parts can dry before solutions runs off, leaving powdery residue	Turn heat down to approximately 140°.

SECTION 4: TROUBLESHOOTING

PROBLEM	POSSIBLE CAUSE	SOLUTION
MACHINE FAILS TO START WHEN "WASHING PARTS" PROCEDURE IS FOLLOWED	Main power disconnect is off	Verify that no service is being performed on the machine, then turn the main power disconnect on.
	Door is not closing properly	Check the door latch and door safety switch; adjust if necessary (See Adjusting the Safety Switch).
	Failed door safety switch	Test the door closure safety switch; replace if necessary (See Door Safety Switch).
	Failed washer cycle timer	Test the wash cycle timer; replace if necessary (See Wash Cycle, Heater and Skimmer Timers).
	Pump is not operating properly	See pump does not operate properly section.
TURNTABLE DOES NOT OPERATE PROPERLY	Turntable switch is OFF	Ensure that the turntable switch is in the on position (See Turntable Switch).
	Parts are obstructing turntable rotation	Check for parts obstructing rotation of the turntable; rearrange if necessary.
	Worn thrust bearing	Inspect the thrust bearing; replace if necessary
	Torque limiter improperly set	Verify the setting on the torque limiter; adjust if necessary
	Failed wash cycle timer	Test the wash cycle timer; replace if necessary (See Wash Cycle, Heater, and Skimmer Timers).
	Failed start capacitor	Test the start capacitor; replace if necessary (See Start Capacitor).
	Failed turntable motor	Contact a licensed electrician to test the motor; replace if necessary (See Turntable Motor).
PUMP DOES NOT OPERATE PROPERLY	Low water level in sump	Check the water level in the sump; add water if necessary (See Low Water Shut-Off System).
	Pump intake is plugged	Check pump intake for obstructions; clean out if necessary.
	Pump overload relay is tripped	Reset the motor overload relay.
	Blown fuse	Check electrical panel for a blown fuse; replace if necessary.
	Line voltage is too low	Contact a licensed electrician to verify that the incoming line voltage meets requirements as specified on the machine ID tag.
	Pump is failed	Contact a licensed electrician to test the pump; replace if necessary.
MACHINE RUSTING INTERIOR	Steam condensing on inside of a lid	Leave lid open during idle periods. Check soap concentration.

SECTION 4: TROUBLESHOOTING

TROUBLESHOOTING THE ELECTRICAL SYSTEM



To troubleshoot the electrical system use the following diagrams to eliminate the possibility of a blown fuse or a bad connection, then refer to Testing Individual Components to determine which component is causing the problem.

WARNING: Electrical shock could cause serious injury or death.

- Electrical troubleshooting should be performed by qualified personnel only.
- Avoid contact with power leads, terminals, and fuses when power is connected.
- Disconnect power to machine before removing fuses or other electrical components.

Troubleshooting the Electrical Panel

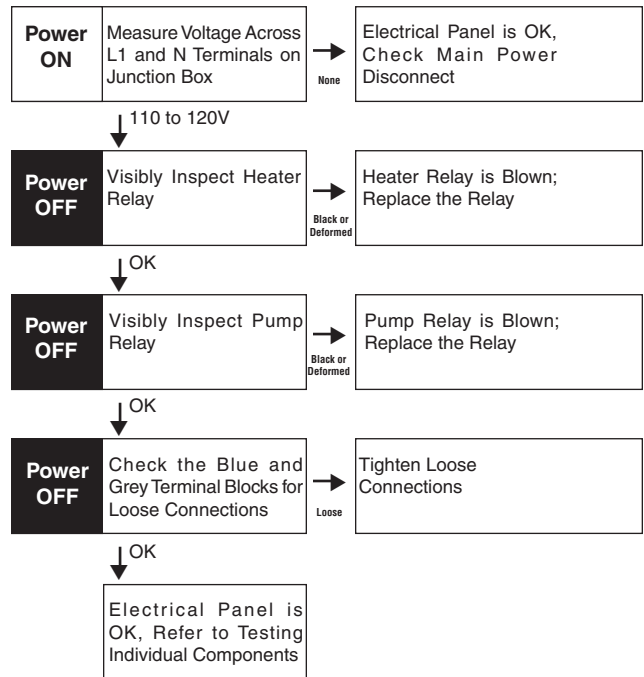
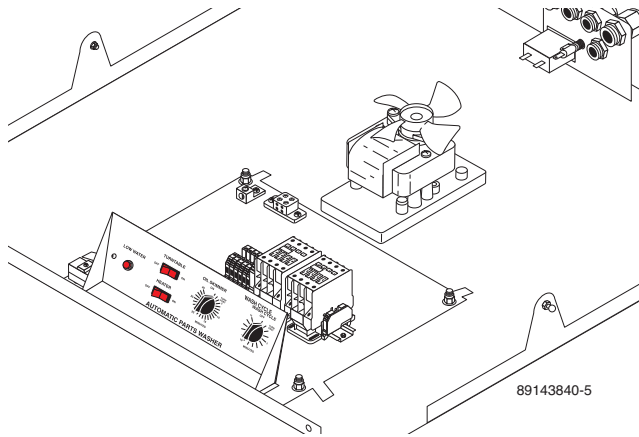

SECTION 4: TROUBLESHOOTING

TESTING INDIVIDUAL COMPONENTS

NOTE: The following troubleshooting procedures require the use of a volt/ohm meter. If you are not familiar with using a volt/ohm meter do not attempt to perform the following troubleshooting procedures. If you need assistance please contact your distributor.

Wash Cycle Timers

Step 1:

Disconnect power to the machine.

Step 2:

Disconnect all wires and remove the timer from the control panel and (See **Timers and Switches on the Control Panel**).

Step 3:

With the timer in the **OFF** position, test for continuity using an ohm meter.

If there **is** continuity the timer is no longer functional; replace the timer.

Step 4:

With the timer in the **ON** position, test for continuity using an ohm meter.

If there **is not** continuity the timer is no longer functional; replace the timer.

Heating Element

Step 1:

Disconnect power to the machine.

Step 2:

Remove the rear panel from the machine (four screws; use a 5/16" wrench or socket – See Figure Below).

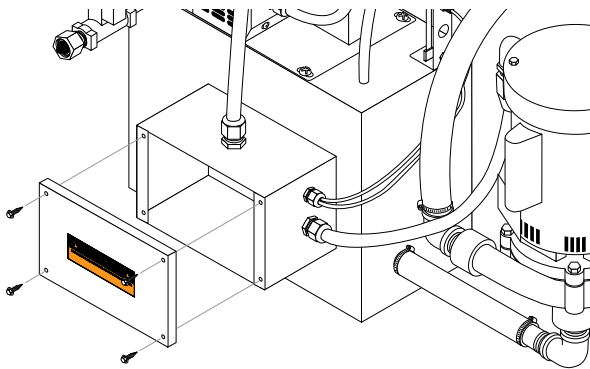

Step 3:

Detach the power leads from the heating element.

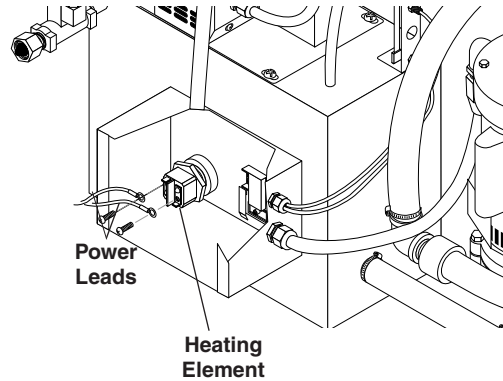

Step 4:

Use an ohm meter to measure the resistance of the heating element. The resistance should be approximately 10 Ohms if not, replace the heating element (See **Heating Element**).

Thermostat

Step 1:

Disconnect power to the machine.

Step 2:

Remove the rear panel from the machine (ten screws; use a 5/16" wrench or socket).

Step 3:

Detach the power leads from the thermostat.

Step 4:

Using a large flat-head screwdriver, pry the thermostat out of the mounting bracket, then remove it from the machine (See Figure Below).

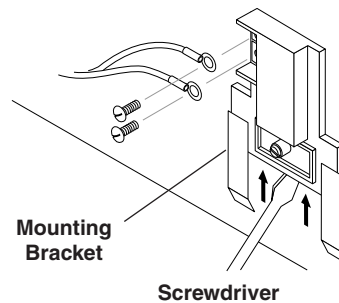

Step 5:

Set the thermostat to 120°F, warm it to just above 120°F, then test for continuity.

If there **is** continuity the thermostat is no longer functional; replace the thermostat.

Step 6:

Allow the thermostat to cool to room temperature, then test for continuity.

If there **is not** continuity the thermostat is no longer functional; replace the thermostat.

SECTION 5: MAINTENANCE AND REPAIR

MAINTAINING THE MACHINE

To ensure optimum performance and trouble-free operation, observe the following maintenance schedule consistently.

Daily Maintenance

- Check the water level; add water if necessary.
- Clean the debris screen.

Weekly Maintenance

- **Detergent Concentration Level:** Check detergent level weekly to maintain concentration level, which decreases when water is added. The pH level of this detergent must be in accordance with the detergent manufacturer's recommendation.
- Remove oil and grease from the wash solution by using the oil skimmer.
- For oily or extremely soiled parts, it is recommended the oil skimmer be operated on a more frequent basis.
- Examine spray nozzles; clean and align if necessary (See **Cleaning and Aligning the Spray Nozzles**).
- Wipe down the exterior of the machine using spray degreaser and a soft, damp cloth. **TO PREVENT ELECTRICAL COMPONENT FAILURE, DO NOT SPRAY THE MACHINE WITH WATER.**

NOTE: Degreaser spray and a damp cloth will usually remove all dirt and grime from the machine. For particularly stubborn soap deposits, use a soft cloth dampened with warm solution from the wash chamber.

Monthly Maintenance

- Drain and clean out the sump chamber (See **Cleaning out the Sump**).

Cleaning and Aligning the Spray Nozzles

To ensure optimum cleaning performance, it is important that you examine the spray nozzles periodically and clean and align them if necessary.

To clean a plugged nozzle, remove it from the spray pipe and use a small wire brush to free the nozzle of any obstructions. When you replace the nozzle on the spray pipe, make sure you align it according to figure on the following page to maintain a proper spray pattern.

NOTE: The spray nozzles are sized and positioned to optimize the distribution of cleaning solution in the wash chamber. If you remove the nozzles make sure you replace them in the correct position on the appropriate pipe. Spray nozzle specifications are stamped on the face of each nozzle, as shown.

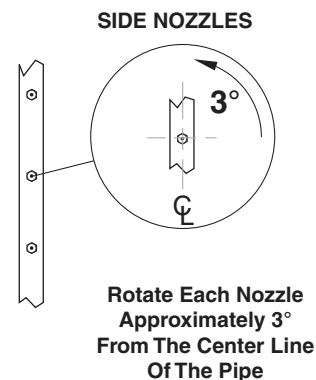
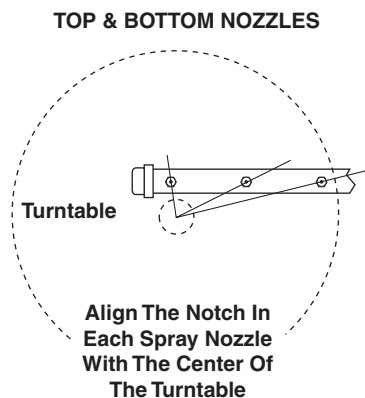

SECTION 5: MAINTENANCE AND REPAIR

Cleaning out the Sump

Step 1:

Remove oil from the cleaning solution using the oil skimmer.

Step 2:

Remove the debris screen.

Step 3:

Drain the wash solution from the sump chamber. To drain the solution either use the sump drain or a small submersible pump.

Step 4:

Remove sand and other debris from the bottom of the sump chamber. To remove the debris either flush it out through the sump drain, or vacuum it out using a wet/dry vac. Dispose of the debris in accordance with applicable local, state, and federal regulations.

NOTE: Take special care to ensure that the heating element and the low-water float are free of debris.

A build up of debris around the heating element will decrease heating performance and may cause the element to overheat and fail. A build up of debris around the float may cause the low water shut-off system to malfunction (See **Low Water Shutoff System**)

Step 5:

Replace the debris screen.

Step 6:

Heat the wash water to operating temperature, then add appropriate amount of factory detergent.

Step 7:

Run the machine through a 15-minute wash cycle.

REPAIRING THE MACHINE

The following procedures outline the steps necessary to replace specific items on the machine that could wear out or otherwise fail.

Heating Element

Required Tools and Equipment

- 5/16" wrench or socket
- 1-1/2" socket and breaker bar
- sealing tape or compound
- medium phillips-head screwdriver

Replacement Procedure

Step 1:

Disconnect power to the machine.

Step 2:

Drain the wash solution from the sump.

Step 3:

Remove the rear panel from the machine (four screws; use a 5/16" wrench or socket – See Figure Below).

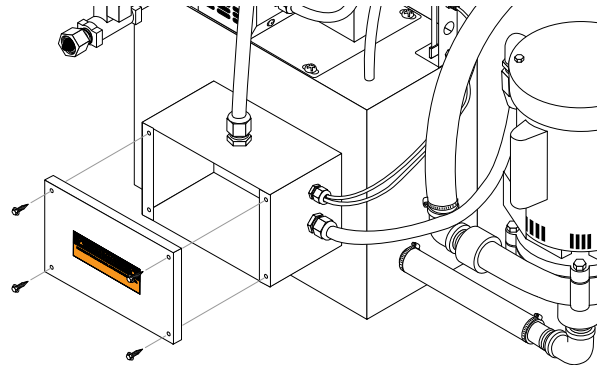

Step 4:

Detach the power leads from the heating element (See Figure Below).

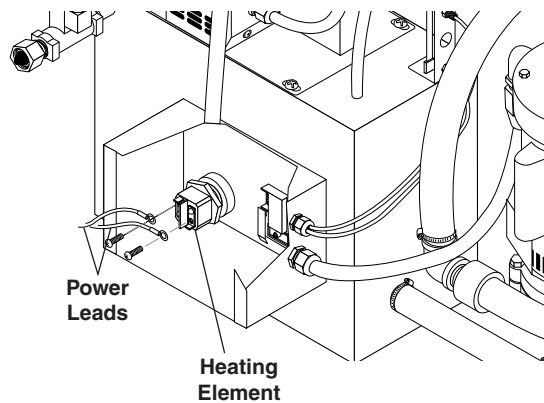

Step 5:

Using a 1-1/2" socket and breaker bar, unscrew the heating element from the machine.

NOTE: Since the heating element is in continuous contact with the cleaning solution the threads may corrode slightly. The element may be difficult to remove. When you install a new heating element, use sealing tape or compound on the threads to deter corrosion, and be sure to install the rubber gasket to prevent leakage.

Step 6:

Install the new heating element. Installation is the reverse of removal.

SECTION 5: MAINTENANCE AND REPAIR

Thermostat

Required Tools and Equipment

- 5/16" wrench or socket
- medium phillips-head screwdriver
- large flat-head screwdriver

Replacement Procedure

Step 1:

Disconnect power to the machine.

Step 2:

Remove the rear panel from the machine (ten screws; use a 5/16" wrench or socket).

Step 3:

Detach the power leads.

Step 4:

Using a large flat-head screwdriver, pry the thermostat out of the mounting bracket, then remove it from the machine (See Figure Below).

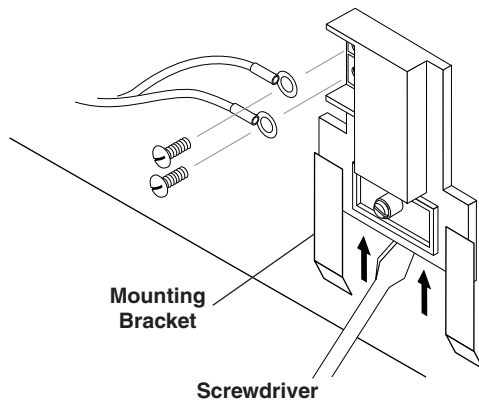

Step 5:

Install the new thermostat. Installation is the reverse of removal.

NOTE: When you install the thermostat make sure you press it firmly into the mounting bracket. In order to operate correctly, the thermostat must be in direct contact with the rear wall of the sump chamber.

Timers and Switches on the Control Panel

Required Tools and Equipment

- 5/16" wrench or socket
- 1/2" wrench or deep socket
- small phillips-head screwdriver
- small flat-head screwdriver

Replacement Procedure

Step 1:

Disconnect power to the machine.

Step 2:

Close the lid.

Step 3:

Remove the lid cover (four screws use a 5/16" wrench or socket – See Figure Below).

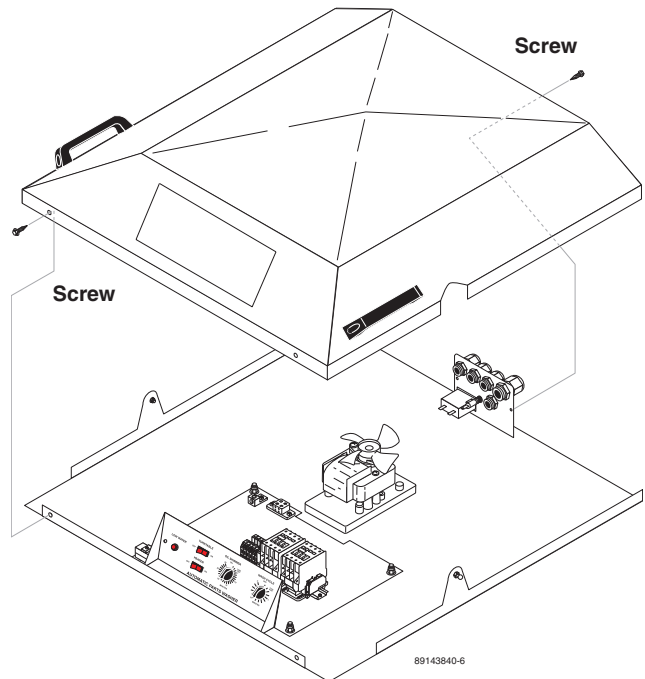

Step 4:

From the rear of the control panel, remove the power leads from the component you wish to replace, then remove the component (See Figure Below).

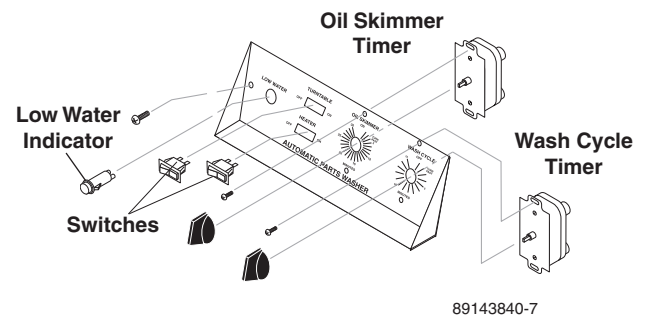

Step 5:

Replace the component, then reassemble the lid cover.

Step 6:

Ensure thermostat is set to 180°F.

SECTION 5: MAINTENANCE AND REPAIR

Torque Limiter

The torque limiter prevents the turntable motor from burning out in case a part falls off the turntable and obstructs rotation. The torque limiter is pre-set at the factory, but you may need to adjust it if the turntable begins to slip or bind.

Adjusting the Torque Limiter

To adjust the torque limiter, perform the following procedure;

Step 1:

Raise the lid.

Step 2:

Loosen the torque limiter set screw (use a 1/8" allen wrench – See Figure Below).

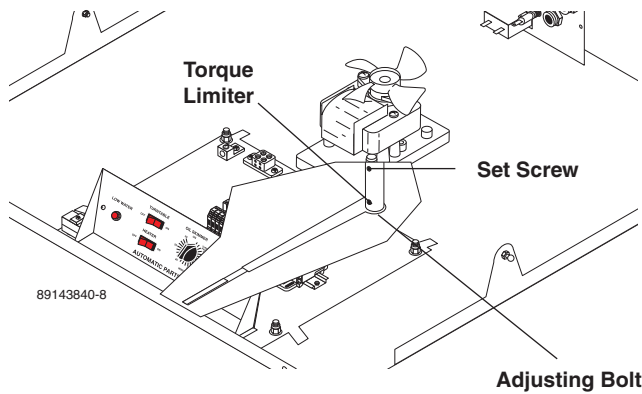

Step 3:

Rotate the torque arm 180°

Step 4:

Clamp the hub against the top spray arm with a pair of locking pliers, then use a spring scale on the end of the torque arm to measure the torque setting (See Figure Below).

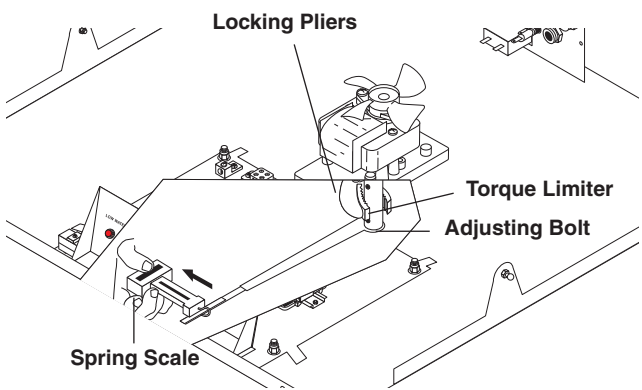

The torque arm should begin to slip at 7 pounds. If it slips at **less than** 7 pounds, tighten the adjusting bolt. If it slips at **greater than** 7 pounds, loosen the adjusting bolt.

Step 5:

Remove the locking pliers from the hub, then tighten the set screw.

Turntable Motor

The turntable motor is located near the main electrical panel beneath the lid cover. To replace the turntable motor, perform the following procedure:

Step 1:

Disconnect power to the machine.

Step 2:

Close the lid.

Step 3:

Remove the lid cover (four screws use a 5/16" wrench or socket – See Figure Below).

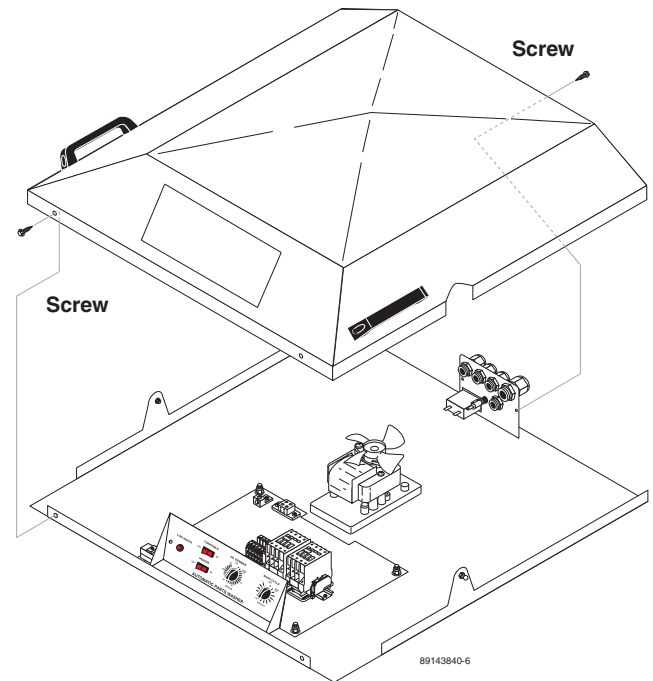

Step 4:

Raise the lid.

SECTION 5: MAINTENANCE AND REPAIR

Step 5:

Loosen the retaining screw to remove the torque arm assembly from the drive shaft (use a 1/8" allen wrench – See Figure Below).

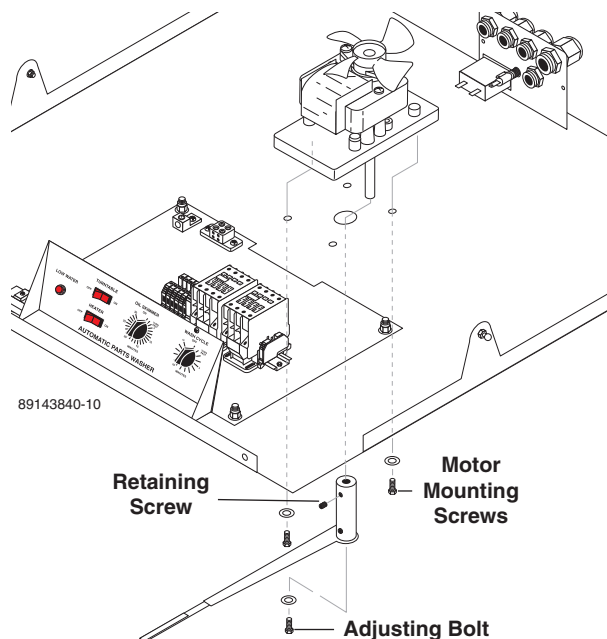

Step 6:

Remove the four turntable mounting screws (See Figure Above).

Step 7:

Close the lid.

Step 8:

Disconnect the power leads from the motor, then remove the motor from the lid (See Figure Below).

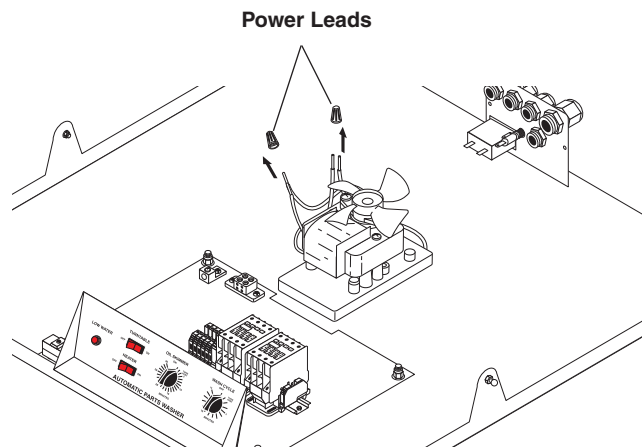

Step 9:

Install the new motor. Installation is the reverse of removal.

Using the Oil Skimmer System

The oil skimmer system is most effective if used when the cleaning solution in the sump is cool.

The frequency at which you must remove the oil from the wash solution will depend on machine usage. Under typical operating conditions you may need to remove the oil every day.

IMPORTANT: The skimmer motor is equipped with a thermal overload switch which protects the skimmer from overheating. If you attempt to use the oil skimmer system when the wash solution is hot, the thermal overload will probably trip and the motor will shut off until it cools. Under normal skimming conditions (when the wash solution is cool) the thermal overload should not trip.

To remove oil from the cleaning solution, perform the following procedure:

Step 1:

Allow the machine to sit idle for at least 30 minutes to allow the oil to float to the surface of the wash solution.

Step 2:

Ensure that the oil collection container is in place (See Figure Below), then turn the skimmer timer to the "ON" position.

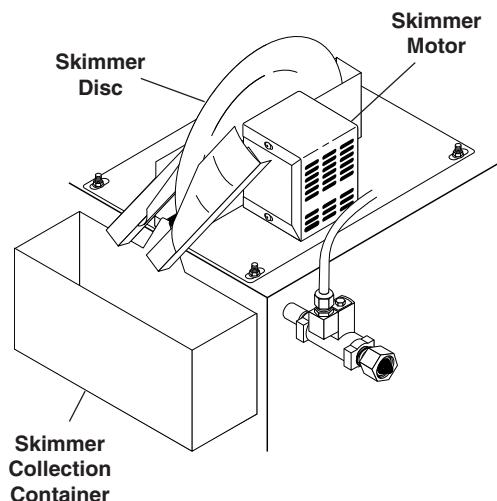

Allow the oil skimmer to operate until it is no longer extracting oil from the cleaning solution.

Tip: While extracting oil from the cleaning solution, oil will flow off the wiper blades in a fine continuous stream. Water will flow off the blades in droplets. Once droplets begin to flow off the wiper blades, stop the skimmer motor.

Step 3:

Dispose of the oil in the collection container in accordance with local and state regulations, then replace the container.

EXPLODED VIEW - 115V ELECTRICAL PANEL

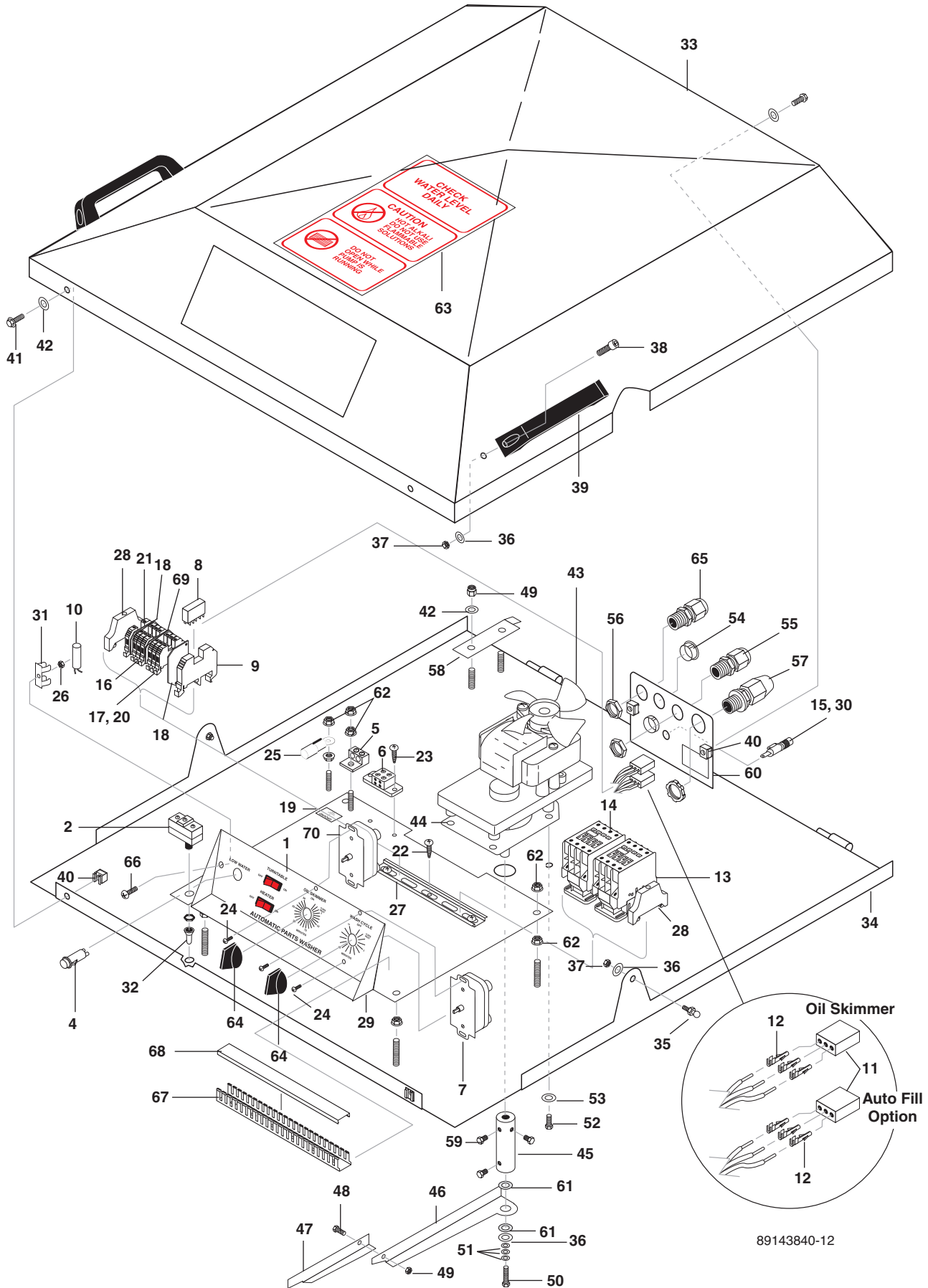

89143840-12

115V ELECTRICAL PANEL PARTS LIST

ITEM	PART NO.	DESCRIPTION	QTY	ITEM	PART NO.	DESCRIPTION	QTY
1	8.714-820.0	Label, Control H ₂ O-2412, SC-2412D 115V	1	35	9.804-207.0	Ball Stud, 5/16"-18 UNC, 10mm 2A Stud	2
2	9.804-510.0	Switch, Lid/Door, 15 Amp, Non Enclosed	2	36	9.718-980.0	Washer, 5/16" Flat SAE	7
3	8.713-328.0	Switch-Lighted Rocker Skimmer/TT ON/OFF	2	37	9.802-776.0	Nut, 5/16" ESNA, NC	6
4	8.714-057.0	Light-Indicator Red 120V, 50" Diam	1	38	8.713-246.0	Screw, 5/16"-18 x 1" Socket Head	4
5	8.713-086.0	Ground-Lug 2 Hole Alum	1	39	9.804-203.0	Handle, Door/Strainer	2
6	8.714-164.0	Terminal Block - 2 Position (Surface) BL-BL	1	40	9.802-793.0	Nut, Cage, 1/4" x 16 GA	4
7	8.714-163.0	Timer - 15 Min Spring Wound	1	41	9.802-700.0	Bolt, 1/4" x 3/4", NC HH	4
8	8.713-348.0	Relay, SPDT (K36)	1	42	9.802-802.0	Washer, 1/4", Flat, SAE	6
9	8.713-355.0	Relay Base	1	43	8.714-379.0	Gearmotor, AC Fract 6 RPM 2412 Drive, 120V, 1/2" SS Shaft	1
10	8.713-315.0	Switch-Mercury Tilt	1	44	9.804-247.0	Gasket, Gearmotor Paper Fiberflex	1
11	8.713-603.0	Connector, Electrical 3 Pin Male	2	45	8.714-380.0	Torque, Hub Outlaw	1
12	8.713-604.0	Connector, Elec Pin Fem	6	46	8.913-712.0	Torque Arm	1
13	8.750-866.0	Contactor, 3 Pole 9 Amp (Pump)	1	47	8.913-713.0	Tip Torque, Rotation Arm	1
	8.750-869.0	▲ Contact, NC Aux, Front Mnt	1	48	9.802-700.0	Bolt, 1/4" x 3/4", NF HH	1
14	8.750-864.0	Contactor, 3 Pole 16 Amp (Heater)	1	49	9.802-773.0	Nut, 1/4" ESNA NC	3
	8.750-869.0	▲ Contact, NC Aux, Front Mnt	1	50	8.714-213.0	Bolt, 5/16" x 2" NF HH	1
15	8.716-224.0	Holder, Fuse Block Panel MT	1	51	9.804-238.0	Washer, Belleville (Disc Spring) .317D x .625 OD, .047" THK	3
16	8.716-398.0	Terminal Block, Blue, Entrelec, 125116-01	3	52	8.718-813.0	Screw, 10-32" x 1/2" BH, SOC, SS	4
17	8.716-396.0	Terminal Block, Entrelec, Gray 115-116-07 M4/6	3	53	8.718-568.0	Washer, 1/4" Flat SS Sealing Rub	4
18	8.716-399.0	End Cover, Entrelec, Gray 11836816 P-ON	2	54	9.802-105.0	Plug, 7/8" Hole	2
19	9.800-040.0	Label, Grnd Symbol	1	55	9.802-514.0	Strain Relief, STRT, LQ Tite 3231 Small	1
20	8.716-402.0	Bridge, Fixed, Entrelec, 16897307 per 10-Pole M4/6	3	56	9.802-525.0	Locknut, 1/2" 8463	1
21	8.716-599.0	Terminal Grnd, Green w/yellow	1	57	8.716-547.0	Connector, 1/2" L/T Straight, Black	1
22	8.718-936.0	Screw, #8 x 1/2", Phillips, Zinc Plated	3	58	8.913-749.0	Lid, Hinge Stop	1
23	8.718-937.0	Screw, #8 x 3/4" Phillips, Zinc Plated	2	59	8.725-303.0	Capscrew, 1/4-28 x 5/8 HX AD SS	3
24	8.718-733.0	Screw, 6/32" x 5/8", Rnd, HB	4	60	9.804-297.0	Label, Hour Meter	1
25	8.716-375.0	Terminal, Ring Tonque	2	61	9.804-242.0	Washer, Flat Bronze, 3/8"ID x 3/4"OD x 1/16" THK Thrust Bearing	2
26	9.802-784.0	Nut, 6-32 Keps	1	62	9.802-775.0	Nut, 1/4" Flange, NC	12
27	9.802-457.0	Din Rail, 35mm	7"	63	9.804-224.0	Decal, Caution, Check Water Levels, All Models	1
28	9.804-595.0	End Bracket, Entrelec	2	64	9.804-294.0	Knob, Timer, Black	2
29	8.913-729.0	Control Panel	1	65	9.802-515.0	Strain Relief LQ Tite	1
30	8.714-836.0	Fuse, 3 Amp	1	66	9.802-748.0	Screw 6/32" x 3/8" Rnd	1
31	8.713-316.0	Clip, Mounting (For Merc. Tilt SW)	1	67	8.716-019.0	Channel 1"	12"
32	8.713-105.0	Switch Boot, Threaded	1	68	8.716-021.0	Cover 1"	12"
33	8.913-711.0	Lid, Top 2412	1	69	8.716-400.0	End Cover Blue	1
34	8.913-721.0	Lid 2412	1	70	8.713-357.0	Timer, 30 Min	1

▲ Not Shown

EXPLODED VIEW - 208V, 230V ELECTRICAL PANEL

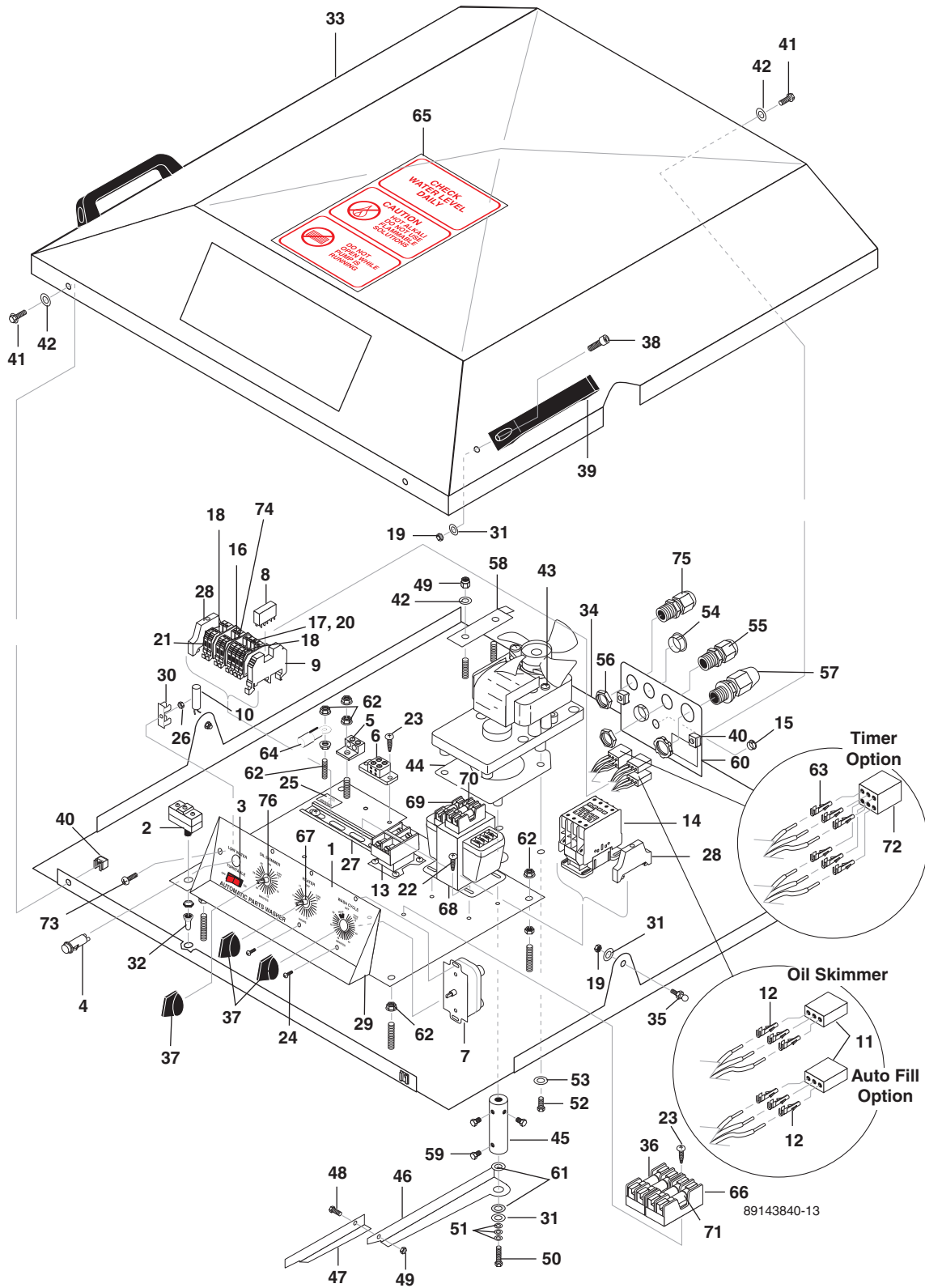

208V, 230V ELECTRICAL PANEL PARTS LIST

ITEM	PART NO.	DESCRIPTION	QTY	ITEM	PART NO.	DESCRIPTION	QTY
1	8.714-821.0	Label, Control, H ₂ O-2412, 230V	1	38	8.713-246.0	Screw, 5/16"-18 x 1" Skt Hd	4
2	9.804-510.0	Switch, Lid/Door, 15 Amp Non Enclosed	1	39	9.804-203.0	Handle, Door/Strainer	2
3	8.713-328.0	Switch, Lighted Rocker Skimmer/TT ON/OFF	1	40	9.802-793.0	Nut, Cage, 1/4" x 16 Ga	4
4	8.714-057.0	Light, Indicator Red 120V, .50" D	1	41	9.802-700.0	Bolt, 1/4" x 3/4", NC HH	4
5	8.713-086.0	Ground, Lug 2 Hole Alum	1	42	9.802-802.0	Washer, 1/4" Flat SAE	6
6	8.714-164.0	Terminal Block, 2 Pos (Surface) BL-BL	1	43	8.714-379.0	Gearmotor, AC Fract 6 RPM 2412 Drive 120V 1/2" SS Shaft	1
7	8.712-832.0	Timer, 60 Min Spring Wound w/Hold Wash	1	44	9.804-247.0	Gasket, Gearmotor Paper Fiberflex	1
8	8.713-348.0	Relay, SPDT (K36)	1	45	8.714-380.0	Torque Hub, Outlaw	1
9	8.713-355.0	Relay, Base	1	46	8.913-712.0	Torque Arm	1
10	8.713-315.0	Switch-Mercury Tilt	1	47	8.913-713.0	Tip Torque Rotation Arm	1
11	8.713-603.0	Connector, Electrical 3 Pin Mal 2	1	48	9.802-700.0	Bolt, 1/4" x 3/4", NC HH	1
12	8.713-604.0	Connector, Electrical Pin Fem	6	49	9.802-773.0	Nut, 1/4" ESNA NC	3
13	8.714-290.0	Contact, Gen Purpose, 2 Pole 230V, 30 Amp	1	50	8.714-213.0	Bolt, 5/16" x 2", NF HH	1
14	8.750-866.0	Contact, 3 Pole, 9 Amp	1	51	9.804-238.0	Washer, Belleville (Disc Spring) .317D x .625 OD .047" THK	3
15	8.714-839.0	Plug, Plastic Black 1/2"	1	52	8.718-813.0	Screw, 10-32" x 1/2" BH, SOC, SS	4
16	8.716-398.0	Terminal Block, Blue Entrelec 125116-01	3	53	8.718-568.0	Washer, 1/4" Flat SS Sealing Rub	4
17	8.716-396.0	Terminal Block, Entrelec, Gray 115-116-07 M4/6	3	54	9.802-105.0	Plug, 7/8" Hole	2
18	8.716-399.0	End Cover, Entrelec, 11836816 P-ON Gray	2	55	9.802-514.0	Strain Relief, STRT, LQ Tite, Sm 1	1
19	9.802-776.0	Nut, 5/16" ESNA NC	6	56	9.802-525.0	Locknut, 1/2" 8463	1
20	8.716-402.0	Bridge, Fixed, Entrelec, 16897307 Per 10 Pole M4/6	3	57	8.716-547.0	Connector, 1/2" L/T Straight Blk1	1
21	8.716-599.0	Terminal, Ground, Green/Yellow	2	58	8.913-749.0	Lid, Hinge Stop	1
22	8.718-936.0	Screw, #8 x 1/2", Phillips, Zinc Plated	11	59	8.725-303.0	Capscrew, 1/4-28 x 5/8 HX HD SS	3
23	8.718-937.0	Screw, #8 x 3/4" Phillips, Zinc Plated	6	60	9.804-297.0	Label, Hour Meter	1
24	8.718-733.0	Screw, 6/32"x5/8", Rnd HB MCH6	1	61	9.804-242.0	Washer, Flat Bronze, 3/8"ID x 3/4" OD x 1/16" Thk Thrust Bearing	2
25	9.800-040.0	Label, Ground Symbol	1	62	9.802-775.0	Nut, 1/4" Flange NC	12
26	9.802-784.0	Nut, 6-32 Keps	1	63	8.713-768.0	Connector, Electrical Pin Male	6
27	9.802-457.0	Din Rail, 35mm	7"	64	8.716-375.0	Terminal, Ring Tongue	2
28	9.804-595.0	End Bracket, Entrelec	2	65	9.804-224.0	Decal, Caution, Check Water Level, All Models	1
29	8.941-092.0	Control Panel	1	66	8.713-290.0	Fuse Block (H2PR) 2 Pole	2
30	8.713-316.0	Clip, Mounting	1	67	8.712-833.0	Timer, 12 HR Spring Wound Heater	1
31	8.718-980.0	Washer, 5/16" Flat	7	68	8.716-875.0	Transformer, 200VA, 230-460V/115V	1
32	8.713-105.0	Switch Boot, Threaded	1		8.716-895.0	Transformer, 200VA, 208V	1
33	8.913-711.0	Lid Top 2412	1	69	8.713-078.0	Fuse, 2 Amp FNM-2	1
34	8.913-721.0	Lid 2412	1	70	8.713-286.0	Fuse, Class 2 Amp	2
35	9.804-207.0	Ball Stud 5/16"-18 UNC 10 mm 2A Stud	2	71	8.713-369.0	Fuse, 25 Amp	2
36	8.713-287.0	Fuse, 12 Amp	2	72	8.713-731.0	Connector, Elecl, 6-Pin Fem	1
37	9.804-294.0	Knob, Timer Black	3	73	9.802-784.0	Screw, 6/32" x 3/8"	1
				74	8.716-400.0	End Cover, Blue, Entrelec	1
				75	9.802-515.0	Strain Relief, STRT, LQ Tite	1
				76	8.713-357.0	Timer, 30 min	1

EXPLODED VIEW - FRONT VIEW

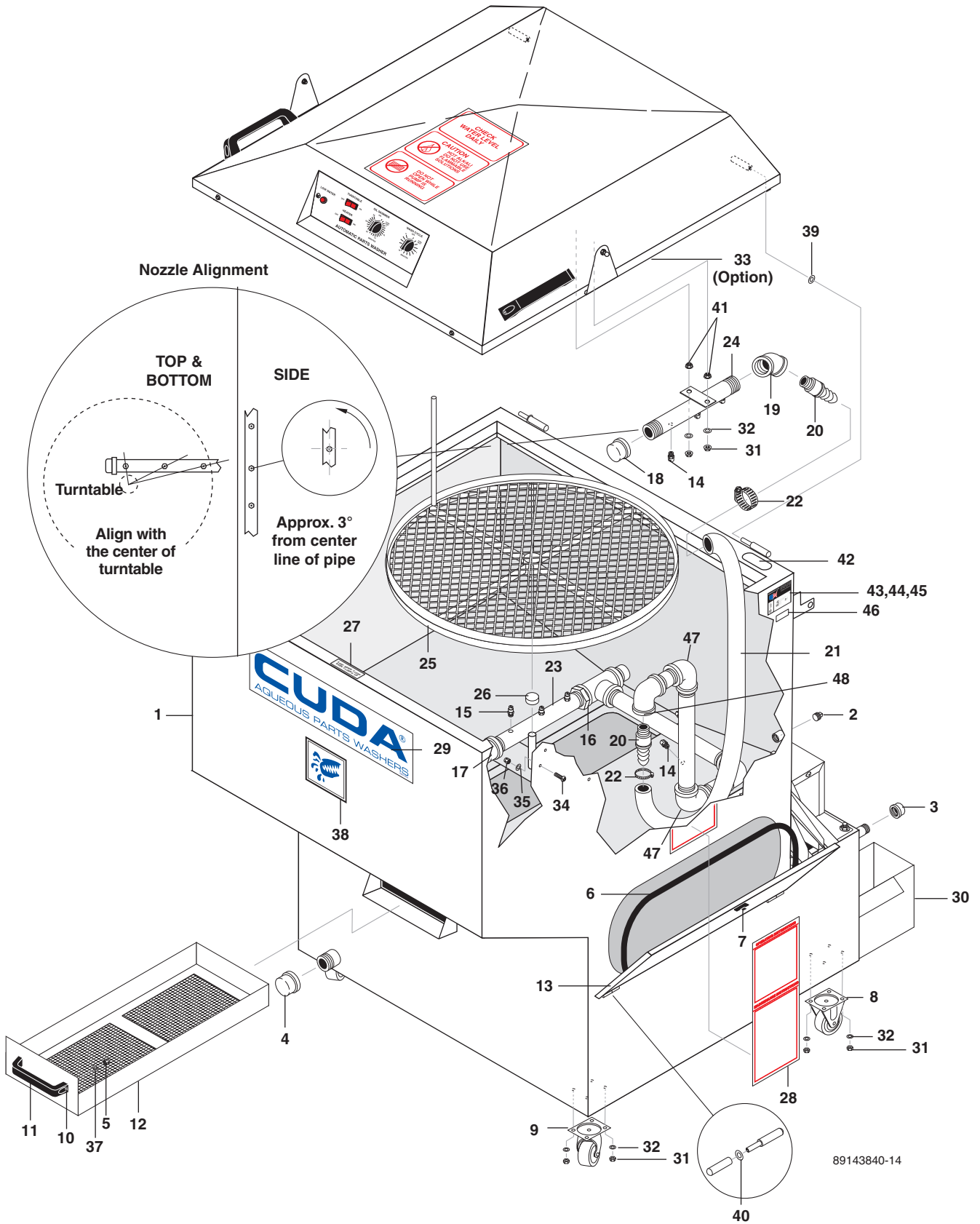

EXPLODED FRONT VIEW PARTS LIST

ITEM	PART NO.	DESCRIPTION	QTY	ITEM	PART NO.	DESCRIPTION	QTY
1	8.913-719.0	Tank Assy 2412	1	18	8.706-320.0	Cap, 3/4" Black Pipe	1
2	8.706-328.0	Pipe, Plug 1/4" Galv.	1	19	8.930-155.0	Elbow, 45°, 3/4" Galv.	1
3	8.706-350.0	Pipe, Cap 1/2" Galv.	1	20	8.706-340.0	Pipe, Barbed, Male NPT 3/4" Black	2
4	8.706-349.0	Pipe, Cap 1-1/2" Galv.	1	21	9.802-261.0	Hose, 3/4" Push-on, per/ft	24"
5	9.802-776.0	Nut, 5/16 ESNA	2	22	9.803-629.0	Clamp, Screw, #16	2
6	8.915-388.0	Seal, Bulb Type (12G) Nitrile, Side Profile	48"	23	8.720-002.0	Spray Pipe 1" x 10"	1
7	9.804-185.0	Latch-Vise Action Side Acc Cover	1	24	8.913-706.0	Assy., Upper Spray Bar	1
8	8.711-919.0	Caster, Fixed, 2-1/2" Polywheel	2	25	8.913-724.0	Turntable Assy	1
9	8.711-920.0	Caster, Swivel, 2-1/2" x 1-1/8" Polyolefin	2	26	9.804-259.0	Thrust Bearing	1
10	8.713-246.0	Screw, 5/16"-18 x 1" Socket Head	2	27	8.904-660.0	Decal, Keep Hands Clear When Closing Lid	1
11	9.804-203.0	Handle, Door/Strainer	1	28	9.804-223.0	Decal, Oper Inst, All Models	1
12	8.913-705.0	Debris, Tray Assy	1	29	9.801-126.0	Label, Cuda 24 x 6	1
13	8.913-727.0	Door Assy, Sump Access	1	30	8.913-702.0	Oil Bucket (Opt)	1
14	8.712-777.0	Nozzle, 50°, #3	5	31	9.802-773.0	Nut, 1/4" ESNA, NC	18
15	8.714-202.0	Nozzle, 80°, #3	3	32	9.802-802.0	Washer, 1/4" Flat, SAE	18
16	8.706-047.0	Pipe, Bushing 1-1/4" to 1" Black	1	33	8.705-962.0	Ring, Containment (Opt)	1
17	8.706-081.0	Cap, Pipe 1 NPT 150WP Non PL	1	34	8.718-813.0	Screw, 10/32 x 1/2, BH, SOC, SS	3
				35	8.718-568.0	Washer, Sealing	3
				36	9.804-567.0	Nut, 10/32 ESNA	3
				37	8.718-980.0	Washer, 5/16" Flat	2
				38	9.801-132.0	Label, Cuda Icon 6"	1
				39	8.725-296.0	Washer, Bullet Hinge 8mm Pin Brass	2
				40	8.725-297.0	Washer, Bullet Hinge 6mm Pin Brass	2
				41	9.802-775.0	Nut, 1/4", Flange NC	2
				42	8.751-325.0	Filter Mediol, 1/4", 2" x 12" x 1"	1
				43	9.800-013.0	Label, Assembled USA Intended for indoor use.	1
				44	9.800-034.0	Label, Clear Lexan	1
				45	N/A	Label, UL/ETL	1
				46	9.804-361.0	Decal, Patent Number	1
				47	8.706-150.0	Elbow, 1"	3
				48	8.706-191.0	Elbow, 1" x 3/4"	1

EXPLODED REAR VIEW PARTS LIST

ITEM	PART NO.	DESCRIPTION	QTY	ITEM	PART NO.	DESCRIPTION	QTY
1	8.714-540.0	Gas Spring, Strut 70# (4514QF) (115V)	2	21	9.802-700.0	Bolt, 1/4" x 3/4", NC	4
	8.724-076.0	Gas Spring 90# (7227SA) (230V)	2	22	8.718-762.0	Screw, 8-32 x 1/2", M PH RDH PL	1
2	9.804-207.0	Ball Stud, 5/16"-18 UNC 10mm 2A Stud	2	23	9.802-423.0	Cord 16/3	60"
3	9.802-776.0	Nut, 5/16" ESNA, NC	2	24	9.804-140.0	Decal, Warning	1
4	8.718-987.0	Washer, 5/16" Flat SS Sealing Rub	2	25	8.713-656.0	Connector, Electrical, 3 Pin Female	1
5	8.716-542.0	Connector, 1/2" L/T Straight, Black	2	26	8.713-768.0	Connector, Electrical Pin Male	3
6	9.802-514.0	Strain Relief, STRT, LQ Tite 3231 Small	1	27	9.800-016.0	Label, Disconnect Power Supply	3
7	9.802-802.0	Washer Flat 1/4"	4	28*	8.715-398.0	Pump Scot, 1/2 HP 115/230V 1 PH	1
8	9.802-448.0	Conduit, Water Tight, Flex 1/2"	36"	29	9.802-517.0	Connector, 1/2 L/T, 90°, Black	1
9	9.802-448.0	Conduit, Water Tight Flex 1/2"	22"	30	9.802-105.0	▲ Plug, 7/8" Hole	1
10	8.714-187.0	Heating Element, 1.8KW/120V/ 1 PH, (115V 1 PH) 1" NPT, MS 9"L w/Seal	1	31	8.706-199.0	Elbow, 1-1/4", 90° Street Galv.	2
	8.712-813.0	Heating Element, 4.5 KW/230V/ 1 PH, 1" NPT MS w/Seal (208V 1 PH, 230V 1 PH)	1	32	8.706-341.0	Pipe, Barbed Male NPT 1-1/4" Galv.	2
11	8.713-593.0	Thermostat, Snap Disc 180° F 1 PH	1	33	8.714-828.0	Hose, 1-1/4" x 6-1/2" Precut Black 200 PSI	1
12	9.804-119.0	Switch, Magnetic Reed Sensor NC	1	34	8.709-081.0	Clamp, Screw, #28	4
13	9.804-118.0	Switch, Magnetic Reed Sensor, NO	1	35	9.804-244.0	Hose, 1-1/4" x 14-1/2" Precut, 200 PSI	1
14	9.804-120.0	Magnet, Reed Sensor Target	1	36	9.802-807.0	Washer, 3/8" SAE Flat	4
15	8.731-134.0	Screw, 4-40 x 1/2" Slotted P/H M/S Zinc	1	37	9.802-779.0	Nut, 3/8" ESNA, NC	4
16	8.718-847.0	Nut, 4-40 Keps, Zinc	1	38	9.802-793.0	Nut, Cage 1-4" x 16 GA	4
17	8.714-226.0	Float, PLY, Cylindrical 2" Dia x 3-3/4"	1	39	9.804-374.0	Decal, Keep Dry	2
18	8.913-717.0	Float Holder	1	40	8.712-896.0	▲ Scoop, Detergent, White 16 oz.	1
19	8.930-331.0	Cover, Heater Element	1			▲ Not Shown	
20	9.802-094.0	Foam strip 1/8" x 1/2" Adhesive Back	30"				
				* 8.713-359.0	Seal Kit		
				8.713-360.0	O-Ring		

AUTO FILL, DETAIL BRUSH & POWER BRUSH OPTIONS

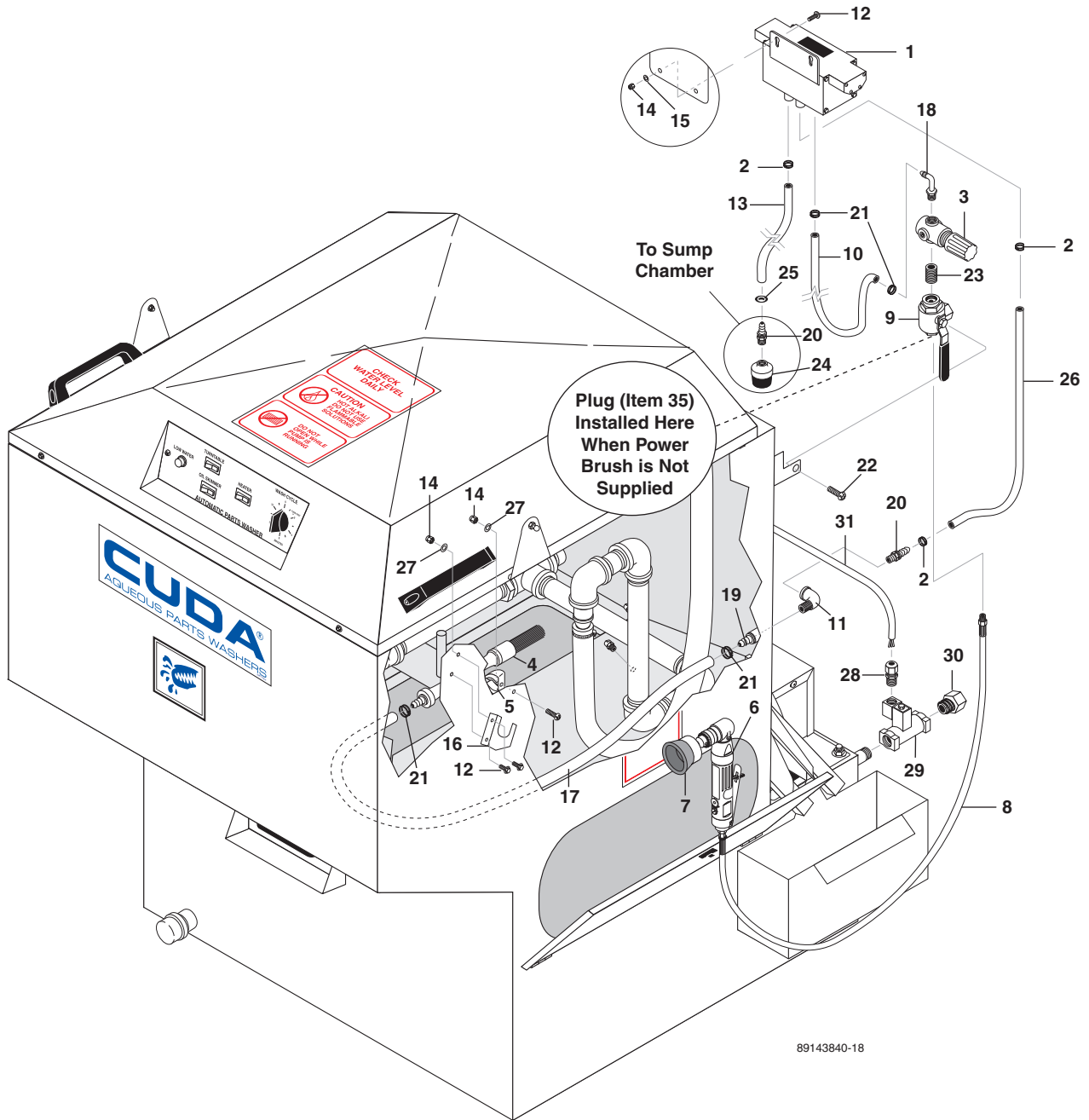

OPTIONS - EXPLODED VIEW PARTS LIST

ITEM	PART NO.	DESCRIPTION	QTY
DETAIL & POWER BRUSH KIT (8.725-245.0):			
1	8.712-778.0	Pump -Air Diaphragm	1
2	8.709-117.0	Clamp, Hose, Uni .62-.75 ST	3
3	8.712-810.0	Regulator -Air 1/4" NPT	1
4	9.804-091.0	Brush -Polyflow (Flo-Thru)	1
5	8.712-815.0	Clip -Detail Brush	1
6	8.712-834.0	Drill -Pneumatic Air R-Angle	1
7	8.712-835.0	Brush -Wire Cup 2-3/4" Dia., 1/4" Stem	1
8	8.712-836.0	Hose -Assembly 1/4" x 60", MPT EA End Power Brush	1
9	8.712-838.0	Pipe -Ball Valve 1/4" 3-Way	1
10	9.802-254.0	Hose, 1/4", Push-on, Fuel Line /Ft	24"
11	8.706-161.0	Elbow, 1/4", Street, 90° Galv	1
12	8.718-813.0	Screw, 10-32" x 1/2" BH, SOC, SS	5
13	8.711-785.0	Hose, 3/8" Push On, /Ft	27.5"
14	9.804-567.0	Nut, 10/32", ESNA	5
15	8.718-959.0	Washer, #10 Flat S/S	2
16	8.915-637.0	Bracket, Power Brush	1
17	8.714-007.0	Hose -1/4" ID x 7/16" OD Buna Tubing 60 Duro	40"
18	8.706-958.0	Hose Barb, 1/4" Barb x 1/4" Pipe, 90°	1
19	8.706-941.0	Hose Barb, 1/4" Barb x 1/4" MI Pipe, Brass	1
20	8.706-950.0	Hose Barb, 3/8" Barb x 1/4" MI Pipe	2
21	6.390-126.0	Clamp, Hose, .46-.54 St	4
22	8.714-255.0	Screw-10-24 x 1/4"SS MS Phil 2	
23	8.706-777.0	Nipple, 1/4" Close-p/n-3326-4	1
24	8.712-808.0	Filter -Inlet (Mesh Ball 1/4" NPT 20 x 20 Mesh) Detail Pump	1
25	9.802-103.0	Bushing, Snap, 5/8"	1
26	8.711-785.0	Hose, 3/8" Push-On, /Ft	18.5"
27	8.718-568.0	Washer, 1/4" Flat SS Sealing Rub	3
ITEM	PART NO.	DESCRIPTION	QTY
DETAIL BRUSH KIT (8.725-251.0):			
1	8.712-778.0	Pump -Air Diaphragm	1
2	8.709-117.0	Clamp, Hose, Uni .62-.75 ST	3
3	8.712-810.0	Regulator -Air 1/4" NPT	1
4	9.804-091.0	Brush -Polyflow (Flo-Thru)	1
5	8.712-815.0	Clip -Detail Brush	1
9	8.712-838.0	Pipe -Ball Valve 1/4" 3-Way	1
10	9.802-254.0	Hose, 1/4", Push-on, Fuel Line /Ft	24"
11	8.706-161.0	Elbow, 1/4", Street, 90° Galv	1

ITEM	PART NO.	DESCRIPTION	QTY
DETAIL BRUSH KIT (8.725-251.0 Cont):			
12	8.718-813.0	Screw, 10-32" x 1/2" BH, SOC, SS	5
13	8.711-785.0	Hose, 3/8" Push On, /Ft	27.5"
14	9.804-567.0	Nut, 10/32", ESNA	5
15	8.718-959.0	Washer, #10 Flat S/S	2
17	8.714-007.0	Hose -1/4" ID x 7/16" OD Buna Tubing 60 Duro	3.33
18	8.706-958.0	Hose Barb, 1/4" Barb x 1/4" Pipe, 90°	1
19	8.706-941.0	Hose Barb, 1/4" Barb x 1/4" MI Pipe, Brass	1
20	8.706-950.0	Hose Barb, 3/8" Barb x 1/4" MI Pipe	2
21	6.390-126.0	Clamp, Hose, .46-.54 St	4
22	8.714-255.0	Screw-10-24 x 1/4"SS MS Phil 2	
23	8.706-777.0	Nipple, 1/4" Close-p/n-3326-4	1
24	8.712-808.0	Filter -Inlet (Mesh Ball 1/4" NPT 20 x 20 Mesh) Detail Pump	1
25	9.802-103.0	Bushing, Snap, 5/8"	1
26	8.711-785.0	Hose, 3/8" Push-On, /Ft	18.5"
27	8.718-568.0	Washer, 1/4" Flat SS Sealing Rub	3
35	8.706-328.0	Plug, Pipe 1/4" NPT Galv.	1
ITEM	PART NO.	DESCRIPTION	QTY
POWER BRUSH OPTION (8.725-258.0):			
6	8.712-834.0	Drill -Pneumatic Air R-Angle	1
7	8.712-835.0	Brush -Wire Cup 2-3/4" Dia., 1/4" Stem	1
12	8.718-813.0	Screw, 10-32" x 1/2" BH, SOC, SS	3
14	9.804-567.0	Nut, 10/32", ESNA	3
16	8.915-637.0	Bracket, Power Brush	1
27	8.718-568.0	Washer, 1/4" Flat SS Sealing Rub	3
ITEM	PART NO.	DESCRIPTION	QTY
AUTOFILL OPTION (8.725-261.0):			
28	9.802-514.0	Strain Relief, STRT, LQ Tite 3231 Small	2
29	8.713-149.0	Solenoid Valve, 1/2" Brass	1
30	9.802-146.0	Swivel, 1/2" MP x 3/4" GHF w/Strainer	1
31	9.802-423.0	Cord, Service, SEO, 16/3, /Ft Coleman	48"
32	8.713-768.0	▲ Connector, Electrical Pin Male	3
33	8.713-656.0	▲ Connector, Electrical 3 Pin Female	1
		▲ Not Shown	

FILTER OPTION 8.725-269.0 - EXPLODED VIEW

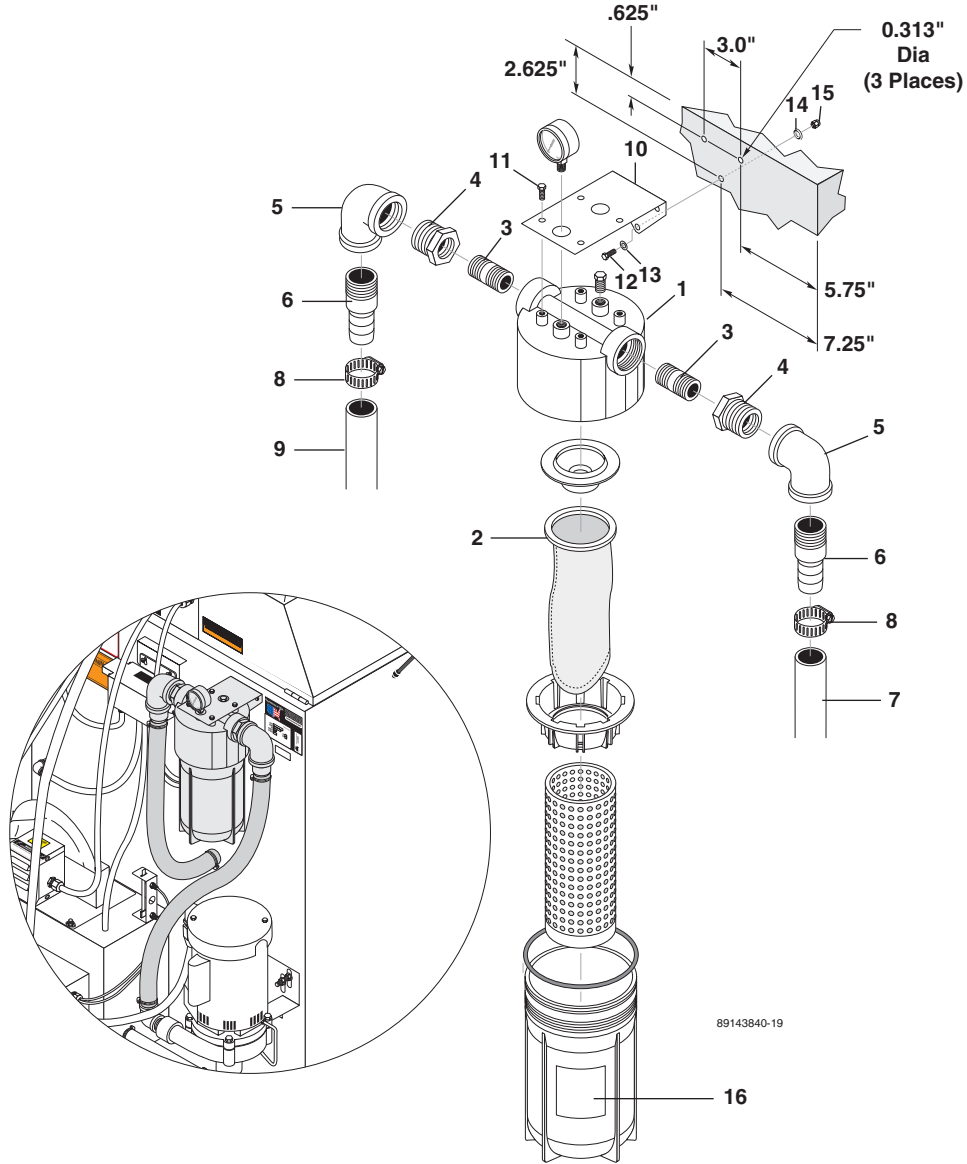

89143840-19

FILTER OPTION - EXPLODED VIEW PARTS LIST

ITEM	PART NO.	DESCRIPTION	QTY	ITEM	PART NO.	DESCRIPTION	QTY
1	8.724-071.0	Filter Housing 4" x 10" W/PSI Gauge	1	7	8.724-082.0	Hose, 1-14" x 25" 200 PSI	1
2	8.724-073.0	Bag, Filter, 4" x 10", Polyester Mesh, 200 MIC	1	8	8.709-081.0	Clamp, Screw #28	4
3	8.724-081.0	Nipple, 1" x 2-1/2" Sch40 Galv	2	9	9.804-244.0	Hose, 1-1/4" x 14-1/2" 200 PSI	1
4	8.706-048.0	Bushing, Pipe 1-1/4" x 1" NPT Galv	2	10	8.930-052.0	Bracket, Filter 2412	1
5	8.706-198.0	Elbow, 1-1/4" Female, 90 ° Galv	2	11	8.724-083.0	Bolt, Tri-Round, Hex Zinc, 5/16-18 x 3/4	4
6	8.706-341.0	Pipe, Barbed Male NPT 1-1/4" Galv	2	12	9.802-700.0	Bolt, 1/4" x 3/4", NC	3
				13	9.802-802.0	Washer, 1/4", Flat	3
				14	8.718-568.0	Washer, 1/4", Sealing	3
				15	9.802-773.0	Nut, 1/4" ESNA	3
				16	8.904-658.0	Decal, Caution Filter Pressure	1

OIL SKIMMER - EXPLODED VIEW

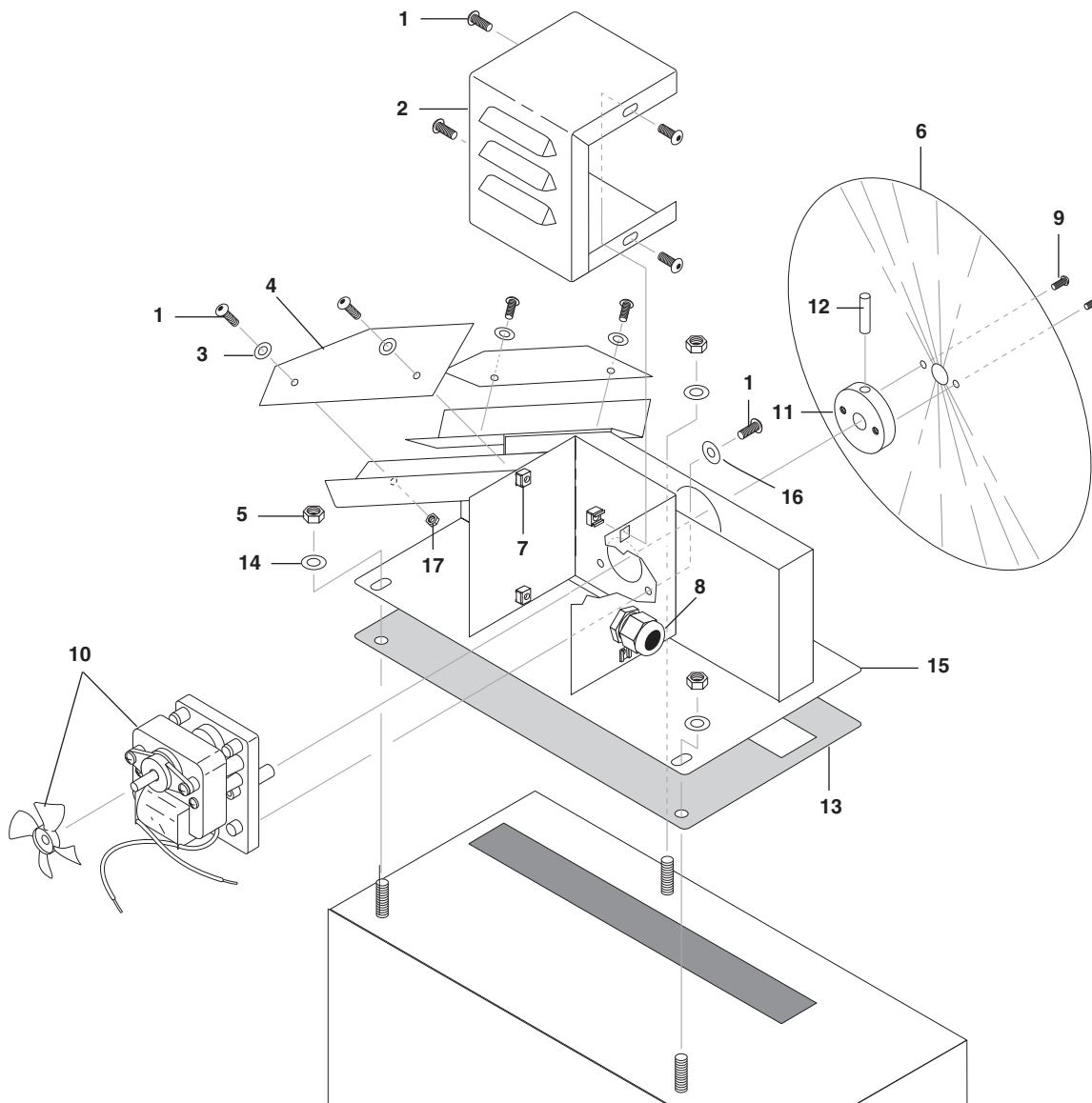

OIL SKIMMER PARTS LIST

ITEM	PART NO.	DESCRIPTION	QTY	ITEM	PART NO.	DESCRIPTION	QTY
1	8.718-813.0	Screw, 10/32" x 1/2" BH, SOC, SS	11	10	8.904-676.0	Motor, Disc Skimmer	1
2	8.913-733.0	Cover, Motor, Disc Skimmer SS	1	11	8.719-987.0	Hub, Disc Mount, Disc Skimmer	1
3	8.718-968.0	Washer #10 Flat Zinc PLT	4	12	8.719-068.0	Pin, Roll 1/8" x 1" Steel	1
4	9.804-102.0	Blade, Wiper, Disc Skimmer SS	2	13	9.804-137.0	Gasket, Skimmer Base	1
5	9.802-773.0	Nut, 5/16 ESNA	3	14	9.802-802.0	Washer, 1/4 Flat	3
6	8.918-672.0	Disc, Skimmer SS	1	15	8.913-732.0	Oil Skimmer, Small	1
7	9.802-791.0	Nut, Cage, 10/32" x 16 Ga.	4	16	8.718-568.0	Washer, 1/4" Sealing	3
8	9.802-514.0	Strain Relief, STRT, LQ Tite	1	17	9.804-567.0	Nut, 10/32 ESNA	4
9	9.804-564.0	Screw, 6-22 x 12	2				



CUDA LIMITED NEW PRODUCT WARRANTY AUTOMATIC PARTS WASHERS

WHAT THIS WARRANTY COVERS

All CUDA automatic parts washers are warranted to the original purchaser to be free from defects in materials and workmanship under normal use, for the periods specified below. This Limited Warranty, subject to the exclusions shown below, is calculated from the date of the original purchase, and applies to the original components only. Any parts replaced under this warranty will assume the remainder of the warranty period.

ONE YEAR PARTS AND 90 DAYS LABOR WARRANTY:

All components and accessories excluding normal wear items as described below. A one year labor warranty will apply if Cuda, Hotsy or Landa parts washer detergent is used (rust and vapor corrosion inhibitor must be used).

WHAT THIS WARRANTY DOES NOT COVER

This warranty does not cover the following items:

1. Normal wear items, such as nozzles, seals, filters, gaskets, O-rings, fuses, calrods, oil skimmer disk and scraper blade.
2. Damage or malfunctions resulting from accidents, abuse, modifications, alterations, incorrect installation, improper servicing, failure to follow manufacturer's maintenance instructions, or use of the equipment beyond its stated usage specifications as contained in the operator's manual.
3. Damage due to freezing, chemical deterioration, scale build up, rust, or corrosion.
4. Damage to components from fluctuations in electrical or water supply.
5. Normal maintenance service, including adjustments, system cleaning, and clearing of obstructions.
6. Transportation to service center, field labor charges, or freight damage.

WHAT YOU MUST DO TO OBTAIN WARRANTY SERVICE

In order to obtain warranty service on items warranted by CUDA, you must return the product to your Authorized Hotsy or Landa Distributor, freight prepaid, with proof of purchase, within the applicable warranty period. Your authorized Distributor will file a claim with CUDA, who must subsequently verify the defect. In most cases, the part must be returned freight prepaid with the claim. For warranty service on components warranted by other manufacturers, your Authorized Distributor can help you obtain warranty service through these manufacturers' local authorized service centers. If you are unable to resolve the warranty claim satisfactorily, write to CUDA at 4275 NW Pacific Rim Blvd., Camas, WA 98607 ATTN: Warranty Dept., detailing the nature of the defect, the name of the Authorized CUDA Distributor, and a copy of the purchase invoice.

Our liability for special, incidental, or consequential damages is expressly disclaimed. In no event shall CUDA's liability exceed the purchase price of the product in question. We make every effort to ensure that all illustrations and specifications are correct, however, these do not imply a warranty that the product is merchantable or fit for a particular purpose, or that the product will actually conform to the illustrations and specifications. Our obligation under this warranty is expressly limited at our option to the replacement or repair at a service facility or factory designated by us, of such part or parts as inspection shall disclose to have been defective. **THE WARRANTY CONTAINED HEREIN IS IN LIEU OF ALL OTHER WARRANTIES, EXPRESS OR IMPLIED, INCLUDING ANY IMPLIED WARRANTY OF MERCHANTABILITY OR FITNESS FOR A PARTICULAR PURPOSE ARE EXPRESSLY LIMITED TO THE DURATION OF THIS WRITTEN WARRANTY.** This warranty gives you specific legal right and you may also have other rights which vary from state to state. CUDA does not authorize any other party, including authorized Distributors, to make any representation or promise on behalf of CUDA, or to modify the terms, conditions, or limitations in any way. It is the buyer's responsibility to ensure that the installation and use of CUDA products conforms to local codes. While CUDA attempts to assure that its products meet national codes, it cannot be responsible for how the customer chooses to use or install the product. Some states do not allow limitations or exclusion or limitation of incidental or consequential damages, so the above limitation or exclusion may not apply to you.

